

## **CONTRIBUTIONS TO THE STUDY OF THE ROMAN POTTERY FROM NOVIODUNUM (ROMANIA, ISACCEA TOWN, TULCEA COUNTY). The 2014 rescue archaeological excavations for the construction of the Border Police Headquarters**



**Florin TOPOLEANU**

Institutul de Cercetări Eco-Muzeale "Gavrilă Simion", Tulcea, e-mail: topflorin@gmail.com

**Ștefan-Emilian GAMUREAC**

Ministerul Culturii, Direcția Patrimoniu Cultural, e-mail: emilian\_gamureac@yahoo.com

**Abstract:** The rescue archaeological excavations for the construction of the Border Police Headquarters nearby Noviodunum (Isaccea, Romania) were carried out in three campaigns: 2011, 2014 and 2018. Due to the great quantity and diversity, the pottery may be published in various steps, as it may be processed by the Laboratory of „Gavrilă Simion” Eco-Museum Research Institute Tulcea, and different categories of artefacts and contexts (lamps, coins, the Roman crypt, the amphorae kiln) will be published separately. This paper is the second one referring to the common pottery discovered, in the majority, in 2<sup>nd</sup>-3<sup>rd</sup> c. AD contexts. Among the categories of pottery, there have been identified various classes as terra sigillata, thin-walled pottery, Pergamenian (Çandarli) ware & imitations, barbotine, Pontic Red Slip ware, Aegean drinking and cooking wares, Pontic, Oriental and Occidental amphorae and table amphorae, local melting pots. Alongside fine and coarse provincial pottery from Moesia, there have been identified some imports as fine pottery from Adriatic regions, amphorae from North Italian and various Pontic provinces. Even the majority of the material is dated during the 2<sup>nd</sup>-3<sup>rd</sup> c. AD few shards can be estimated in the 1<sup>st</sup> c. AD, or even earlier. Also, some pottery examples can be dated for a period after 3<sup>rd</sup> c. AD. To these are added some non-Roman potsherds, characteristic of Thracian Getae tradition.

**Rezumat:** Cercetările arheologice preventive realizate pentru construirea Sediului Poliției de Frontieră din apropierea anticului Noviodunum (Isaccea, județul Tulcea) s-au desfășurat în cursul a trei campanii: 2011, 2014 și 2018. Datorită mării cantități și diversității ceramicii descoperite, acesta poate fi publicat în diverse etape, pe măsură ce este prelucrat de Laboratorul din cadrul Institutului de Cercetări Eco-Muzeale „Gavrilă Simion” Tulcea, iar diferitele categorii de artefacte și complexe (lămpi, monede, cripta romană, cuptorul de amfore) vor fi publicate separat. Prezentul articol este al doilea referitor la ceramica comună, majoritatea fiind descoperită în complexe de sec. II-III p.Chr. Printre categoriile ceramicii, au fost identificate următoarele: terra sigillata, vase cu pereți fini, vase Pergameniene (Çandarli) și imitații, ceramică fabricată în tehnica barbotinei, vase pontice cu slip roșu, vase egeene pentru băut și gătit, amfore pontice, orientale și occidentale și amfore de masă, creuzete fabricate local. Pe lângă vasele din pastă fină și grosieră, din provincia Moesia, au fost identificate importuri precum vase din pastă fină din zona Adriatică, amfore din Italia de Nord, ori din diferite provincii din Pont. Chiar dacă majoritatea pieselor pot fi datate în perioada sec. II-III p.Chr., câteva fragmente ceramice pot fi datate în sec. I. p.Chr., sau chiar mai timpuriu. De asemenea, unele exemplare pot fi datate pentru o perioadă ulterioară sec. III. p.Chr. La acestea se adaugă unele fragmente ceramice neromane, caracteristice pentru ceramica tradițională a geților.

**Keywords:** Noviodunum (ad Istrum), rescue archaeological excavation, Roman pottery, pottery categories, pottery imports

**Cuvinte cheie:** Noviodunum (ad Istrum), cercetare arheologică preventivă, ceramică romană, categorii ceramice, importuri ceramice

## INTRODUCTION

With the arrival of a Roman Rule at the mouths of the Danube, the geographical and strategically<sup>1</sup> position of the existent populated areas become particularly interesting for the newcomers. It is the case of *Noviodunum (ad Istrum)*, an ancient settlement situated on the Southern shore of the Danube, one of the crossing points of the river, destined to become one of the *Classis Flavia Moesica* military bases.

Besides the obvious advantages of the military base with the presence of soldiers – and their payments, which led to the developing the monetary market, as it happens with Roman garrisons arrival throughout the Empire, – the harbour, which led up the river into the interior, was, furthermore, the advantage that connected *Noviodunum* to the *Pontus Euxinus* ports and other commercial routes on the Mediterranean. Considering that the cultivation of the land, which was now the property of the Roman people, and the contribution of those who prospect opportunities for investment, including business with the army, it was to be expected that all these conditions would attract new categories of settlers<sup>2</sup>, by Hellenistic or Roman culture background, using Roman tradition pottery described above.

Concerning the local production of pottery and ceramics, part of the industrial economic activity of *Noviodunum*, one Late Roman rectangular ceramic kiln for bricks and *tegulae* is surely confirmed in the area. Another kiln, used at the beginning of the 4<sup>th</sup> c. AD for firing local produced amphorae and pitchers was discovered during the 2014-2018 excavation.<sup>3</sup> It is worth to mention that the 2<sup>nd</sup>-3<sup>rd</sup> c. AD workshop and the kiln where lamps were locally produced at *Noviodunum* were not found yet. In the same way, there have not been discovered yet the kilns in which the crucibles were used for melting materials.

Despite the lack of sufficient archaeological data for the producers of pottery at *Noviodunum* during the Principate,<sup>4</sup> it is plausible that these producers to be located both in the area of the *municipium* and in its territory,<sup>5</sup> as we know it happens in the Dominate. As for the identification of some products as having a Pontic origin, we know that the fine table wares, alongside the coarse kitchenware, were the major categories manufactured in the nearby province Thrace, in both rural and urban context.<sup>6</sup>

The pottery to be described here is grouped by ware types and origin, not necessarily by the places of discovery, approaching the range of the vessel-forms. Even if for good reasons, this study was intended to be published by a systematic approach of the archaeological contexts, some factors as the elapsed time since 2014 archaeological excavation moment and the incomplete character of the artefacts processing, did determine our analyze in these conditions, by the postponement of a monographic study.

First of all, medieval pottery and other medieval or modern discoveries are not making the object of the present paper. Secondly, a big part of the Roman discoveries are excluded from various reasons from this paper: the metal, bones, part of the Roman pottery from the crypt, description of the pits and tombs, along with a consistent lot of Roman 4<sup>th</sup> c. AD pottery from the pottery workshop and kilns discovered in the Northern side of the excavated area.

---

<sup>1</sup> Baumann 2008, 191.

<sup>2</sup> Magie 1950, 53.

<sup>3</sup> Topoleanu 2018 (2020).

<sup>4</sup> Honcu 2017, 33-37.

<sup>5</sup> Baumann 1995; Baumann 2017, 157.

<sup>6</sup> Harizanov 2020, 124.

Making a parallel between the epigraphic finds at *Noviodunum*<sup>7</sup> and the archaeological funerary discoveries<sup>8</sup> from 2<sup>nd</sup>-3<sup>rd</sup> c. AD *Noviodunum* necropolis, V.H. Baumann was counting 19 Greek-oriental names, one African and 12 Roman names attested<sup>9</sup>, and the list is growing by other papers,<sup>10</sup> concluding that the different rites attested here were in relation with different ethnic groups, especially South – Balkan and Anatolian.<sup>11</sup> As explicit discussion at this point, we should emphasize that there is no special linkage between the ethnic origin of the population and the origin of the pottery provenance, due to the characteristics of the commercial reasons of the Roman economy. According to these studies, a majority of the inhabitants of the settlement of *Noviodunum* were having non-Italic origins, being probably initially of peregrine origins, embracing gradually some of the Roman culture and habits, and using traditional provincial Roman pottery. Excepting the soldiers, but not entirely, they were probably involved in the economy performing agricultural and industrial activities, including the commercial opportunities offered by the location of this Roman *limes* outpost situated *ad ripam fluminis*. The wide spectrum of forms and diverse origins of the pottery reflects the fluvial position of the *Noviodunum*, part of a network of ports and ports facilities, used for both military and commercial purposes.<sup>12</sup>

## THE CONTEXT

The Roman discoveries are structured into two types of findings: funerary monuments/tombs and pits. The most important funerary monument is a Roman crypt containing few skeletons, which are described above.

**The crypt<sup>13</sup> – T3/T4, Context 3.** It is the only monument built with stone and bricks wall, situated in the geographically highest point of the area of excavations. The crypt was excavated into the yellow loess and was built from inside. For this crypt were used small and medium stone blocks mixed with bricks in the *opus incertum* technique. On the inside, in certain areas, is preserved some portions of white plaster, by 1-2 cm thickness containing small traces of red painting. Unfortunately, the tomb was robbed in antiquity, and the roof was destroyed a long time ago, and the Eastern and Northern sides were dismantled. The shape of the construction is rectangular, with sides of 3.30-3.85 m. There have been discovered 11 coins dating the construction from Florian (276 AD), Diocletian (285-286, 295-297 AD), Constantin I (306-307, 313-317 AD) and other coins from 4<sup>th</sup> century AD, dating the use of the crypt during the end of 3<sup>rd</sup> to the 4<sup>th</sup> c. AD, and possibly later. The complex contains a small admixture of earlier pottery examples, very fragmentary, which is not consistent with the majority of the material date.

---

<sup>7</sup> For the epigraphic dossier of Noviodunum, see ISM V.

<sup>8</sup> Simion 1994.

<sup>9</sup> Baumann 2008, 193.

<sup>10</sup> Topoleanu, Zahariade 2017. Apparently a list of the names of some soldiers (of peregrine origins, most likely local inhabitants) in military service in one of the detachments of the Roman army at Noviodunum.

<sup>11</sup> Simion 1994, 91, 124.

<sup>12</sup> Bounegru 2006, 109.

<sup>13</sup> Topoleanu *et alii* 2015, 208.

In the excavated area were discovered over 20 pits from Roman times, and many of them contain only a few atypical shards. Still, in some pits was discovered a great quantity of pottery, as follows:

**T1, Context 1.** This pit is cylindrical in shape, with a diameter of 1,30/1,40 m. The depth of this pit is 2,90 m, and inside was discarded a great amount of pottery as kitchenware, pots and casseroles, lamps, Pontic *sigillata* fragments, glass and bones.

**T6, Context. 3.** The pit has an oval shape with a diameter of 1,10/1,50 m, being designed in steps, with total deep of 1,60 m. The most representative pottery shards are Pergamenian ware, Pontic *sigillata* fragments, *Euctemon* type lamps, attic imports of lamps, glass decorated with a volute translucent model, translucent coups, some iron objects as a key and two fishing hooks, a blade of *falx silvatica*, alongside with a coin from Probus (276-282 AD).

**T7, Context 10.** This pit was excavated in 2011, during the field survey and the material was already published. The research was completed during the 2014 campaign of archaeological excavations. The pit has an irregular shape in *grundriss* (the diameter is between 2,90 m and 3 m), having a maximum depth of 2,20 m. Considering that the pottery was published, we summarize that the most important discovery is represented by diverse early Roman pottery, along with three intact archetypes, five moulds, and several complete or fragmented lamps made with the respective moulds.<sup>14</sup>

It seems that in ancient times, during the 2<sup>nd</sup> and 3<sup>rd</sup> century AD, the *genius loci* was guarding a desolate place, situated alongside Danube shores, at the limit of the civilian settlement, a place used for wasting pits or randomly isolated graves. During the beginning of the 4<sup>th</sup> century, the Northern side of this area came into use for industrial purposes, considering the existence of the pottery kilns. The area was the object of flooding and erosion, at the mercy of the elements of the *Danubius flumen* and for this reason, was not fit for housing.

### TERRA SIGILLATA

1. T<sup>15</sup> 6, C<sup>16</sup> 3, bowl *terra sigillata*, a fragment of wall, p.h.<sup>17</sup>–3 cm, p. length–4.5 cm, oxidative firing, fine reddish fabric, red/browning slip at the inside and outside. Surface colour: Munsell 2.5YR 4/8 red. Core colour: Munsell 5YR reddish-yellow. Stamped figure representing a rider. Rogers 1999, PATERNUS II: p. 417, pl. 79/36, p. 470, pl. 132/11 (X-5) (Central Gaul).
2. Crypt, T3/4, C3, bowl Dragendorff 37 *terra sigillata*, fragment of rim, r.d.–20 cm, p.h.–3 cm, fine reddish fabric, thick red slip at the interior and exterior, Munsell 10R 4/8 red.

<sup>14</sup> Topoleanu, Chrzanovski 2016; Topoleanu *et alii* 2014.

<sup>15</sup> T = Trench.

<sup>16</sup> C= Context.

<sup>17</sup> p.h. = preserved height; r. d. = rim diameter.

### ÇANDARLI WARE & PERGAMENIAN IMITATIONS

3. T 1, C 1, bowl, fragment of rim, r.d.–12 cm, p.h.–3 cm, fine reddish fabric, red thick slip at the inside and outside, Munsell 5YR 7/8 reddish-yellow. Çandarli form 3. 2<sup>nd</sup>-3<sup>rd</sup> c. AD.
4. T6, C3, bowl, a fragment of the upper part, r.d. 14 cm, p.h. 3 cm, fine, reddish fabric with rare limestone particles in composition, thick red slip at the inside and outside, Munsell 10R 5/8 red. Probably Çandarli form 3. 2<sup>nd</sup>-3<sup>rd</sup> c. AD.
5. T1, C1, bowl or basin, a fragment of the rim, length 4,5 cm, width 4 cm, fine, pink fabric, brown gloss at the interior and exterior, Munsell 2.5YR 3/6 dark red. Çandarli form 1. 2<sup>nd</sup>-3<sup>rd</sup> c. AD.
6. T1, C 1, plate, a fragment of the rim, r.d.–20 cm, p.h.–2,5 cm, fine, reddish fabric with rare black particles, thick brownish-red slip at the inside and outside, Munsell 2.5YR 6/8 light red. Possibly a Pontic product, imitating Çandarli quality and colour. Suceveanu 2000, type XIX, 77-80, pl. 29/1, pl. 30/14-16 (Histria, “Pontic” imitations of Çandarli).

### PONTIC POTTERY

#### Pontic Barbotine

7. T1, C1, cup, a fragment of the rim, r.d.–16 cm, p.h.–3.5cm, fine reddish fabric with black microparticles, thick dark red slip, Munsell 2,5 YR 5/8 red. The shard is decorated in the *barbotine* technique. Baumann 2010, 115, catalogue no. 3 (Noviodunum), 2<sup>nd</sup>-3<sup>rd</sup> c. AD.; Sultov 1985, two-handle earthenware, table XXXV/4, type 1b, 76; table XXXVIII/7-9, type 11a-11b (Hotnica, Pavlikeni, Butovo); Nuțu, Costea 2010, 150, pl. 2/1, (Aegyssus).

#### Pontic Red Slip ware

##### Pontic Bowls

8. T17, *passim*, plate, fragment, p.h.–5 cm, r.d.–19 cm, oxidative firing, fine brick colour fabric with silver mica, red slip at the inside and outside. Fabric colour: Munsell 5YR 7/8 reddish-yellow. Slip colour: Munsell 7.5YR 7/8 reddish-yellow. The rim is flat, slightly inclined to the inside; the wall is decorated with concentric circles at the bottom. Suceveanu 1998, 222, pl. VIII/22 (Fântânele, 3<sup>rd</sup> c. AD); Suceveanu 2000, 40, bowls type IX, pl. 11/4, 6 (Histria, 2<sup>nd</sup> c. AD);
9. T3, Roman crypt, bowl fragment, p.h.–5 cm, r.d.–12,5 cm, oxidative firing, fine reddish fabric with silver mica and limestone microparticles, reddish slip at the inside, Munsell 7.5YR 8/6 reddish-yellow. The rim is curved to the outside; the base has a foot ring, Barnea *et alii* 1957, fig. 14/2 (Noviodunum);
10. T1, C.1, bowl, a fragment of the rim, p.h.–4 cm, r.d.–18 cm, fine reddish fabric with rare limestone particles in composition, red thick slip at the inside and partially at the outside, Munsell 2.5YR 6/8 light red. Suceveanu 1998, 222, pl. VIII/22 (Fântânele, 3<sup>rd</sup> c AD); Suceveanu 2000, 40, bowls type IX, pl. 11/4, 6 (Histria, 2<sup>nd</sup> c. AD);
11. T6, C 3, bowl, fragment of upper part, r.d.–28 cm, p.h.–3 cm, coarse brick color fabric with sand and limestone particles, Munsell 5YR 6/4 light reddish brown. Barnea, Barnea 1984, pl. VII/8 (Noviodunum); Băjenaru 2013, (bols cannelés, “peut être produit dans les villes oust-pontiques”), pl. 11/82; Honcu 2017 bowls type XVI, 2<sup>nd</sup>-3<sup>rd</sup> c. AD, p. 121, pl. XXVI/252-256; Suceveanu 2000, 51, bowl type XIII, pl. 16/2, “produit probablement histrien”, 2<sup>nd</sup>-3<sup>rd</sup> c. AD (Histria);

12. T1, C1, bowl, a fragment of the base, base d.–5 cm, p.h.–2 cm, oxidative firing, fine, reddish fabric, red paint at the inside and partially outside, ring foot, Munsell 10R 4/8 red;
13. T1, C1, deep bowl, a fragment of the rim, r.d.–14 cm, p.h.–2.5 cm, oxidative firing, fine, greenish-grey colour fabric, grey slip, Munsell 2.5Y 4/2 dark greyish brown. The rim is thickened in the form of a collar around the neck of the bowl. Nuțu *et alii* 2014, 67, pl. 16/117 (Niculițel, 2<sup>nd</sup> c. AD); Suceveanu 2000, type XX, pl. 31/6 (Histria); Hayes 2008, fig 26/825 (Athenian Agora, second part of the 2<sup>nd</sup> c. AD); Zhuravlev 2002, “Pontic sigillata” fig. 16/7; Klenina 2006, 97, type 5;
14. T6, C3, bowl, a fragment of the upper part, r.d.–12,5 cm, p.h.–3,5 cm, fine yellow-greyish fabric, brownish-yellow colour coating at the inside and outside, Munsell 7.5YR reddish-yellow. Possibly local/regional red slip ware. Barnea *et alii* 1957, fig. 14/2 (Noviodunum);
15. T6, C 3, bowl, fragment, h.–7 cm, r.d.–18 cm, base d.–6 cm, oxidative firing, fine brown fabric, red slip at the inside and partially at the outside, secondarily fired at the outside, Munsell 7.5YR 6/8 reddish-yellow. Ring – foot, the rim is presenting a small ridge on the top. Probably a Pontic imitation of *sigillata*. Suceveanu 1998, 222, pl. VIII/22 (Fântânele, 3<sup>rd</sup> c. AD); Suceveanu 2000, 40, bowls type IX, pl. 11/4, 6 (Histria, 2<sup>nd</sup> c. AD).

#### Pontic plates & tray

16. T6, C3, tray, flat handle, p. length–7.5 cm, oxidative firing, fine reddish fabric, no visible clasts in a matrix, Munsell 7.5 YR 7/8 reddish-yellow. The handle of the tray is decorated with vegetal motifs. Zhuravlev 2002, 276, Fig. 24-1, 2<sup>nd</sup>–first half of the 3<sup>rd</sup> c. AD; Nuțu, Costea 2010, pl. 3/13, 153, platter (Aegyssus); Nuțu *et alii* 2014, fig. 1/13 (Aegyssus);
17. T1, C1, a fragment of the rim, p. h.–2.5 cm, r.d.–28 cm, fine light reddish colour fabric with whitish particles in composition, thick red slip Munsell 10 R 5/6 red. Băjenaru 2013, “plat”, 67, pl. 11/89 (Tomis); Suceveanu 2000, 53, pl. 18/5 (Histria);
18. T6, C3, plate, a fragment of the upper part, r.d.–26 cm, p.h.–7 cm, semi-fine, reddish fabric with iron oxide and silver mica in composition, dark red paint at the outside, Munsell 7.5YR 6/8 reddish-yellow. Vertical rim, carinated profile. Simion 1984, 87, pl. XVII/7-8 (Noviodunum); Zhuravlev 2009, Fig. 9/65, form 4.2. (Pontic plates, 2<sup>nd</sup>-3<sup>rd</sup> c. AD); Băjenaru 2014, 107, fig. 2/12 (Histria); Suceveanu 2000, type XVIII, pl. 26/12 (Histria);
19. T6, C3, plate, fragmentary, h.–8,5 cm, r.d.–25 cm, base d.–8 cm, semi-fine, reddish fabric with limestone particles in composition, traces of reddish paint at the inside and partially at the outside, secondarily fired at the outside, Munsell 7.5YR 8/6 reddish-yellow. The plate is decorated at the outside with parallel, roulette vertical lines. Local Pontic red –slip ware. Opaïț 1980, 336 (local Pontic imitation of Pergamenian bowl), pl. X/5, (2<sup>nd</sup>-3<sup>rd</sup> c. AD, Troesmis);
20. T6, C3, plate, fragmentary, h.–9.5 cm, r.d.–21 cm, base d.–8 cm, semi-fine, brick colour fabric with limestone particles and red particles, red paint at the inside and partially at the outside, Munsell 5YR 6/8 reddish-yellow. Vertical rim, ring – foot. Local Pontic red –slip ware. Opaïț 1980, 336 (local Pontic imitation of Pergamian bowl), pl. X/5, (2<sup>nd</sup>-3<sup>rd</sup> c. AD, Troesmis);
21. T6, C3, plate, a fragment of the rim, r.d.–24.5 cm, p.h.–4 cm, fine, reddish fabric, thick red slip at the inside and outside, Munsell 10 R 5/8 red. Pontic or local *sigillata* bowl. Opaïț 1980, 336 (local Pontic imitation of Pergamenian bowl), pl. X/5, (2<sup>nd</sup>-3<sup>rd</sup> c. AD, Troesmis); Suceveanu 2000, 60-61, pl. 22/6.

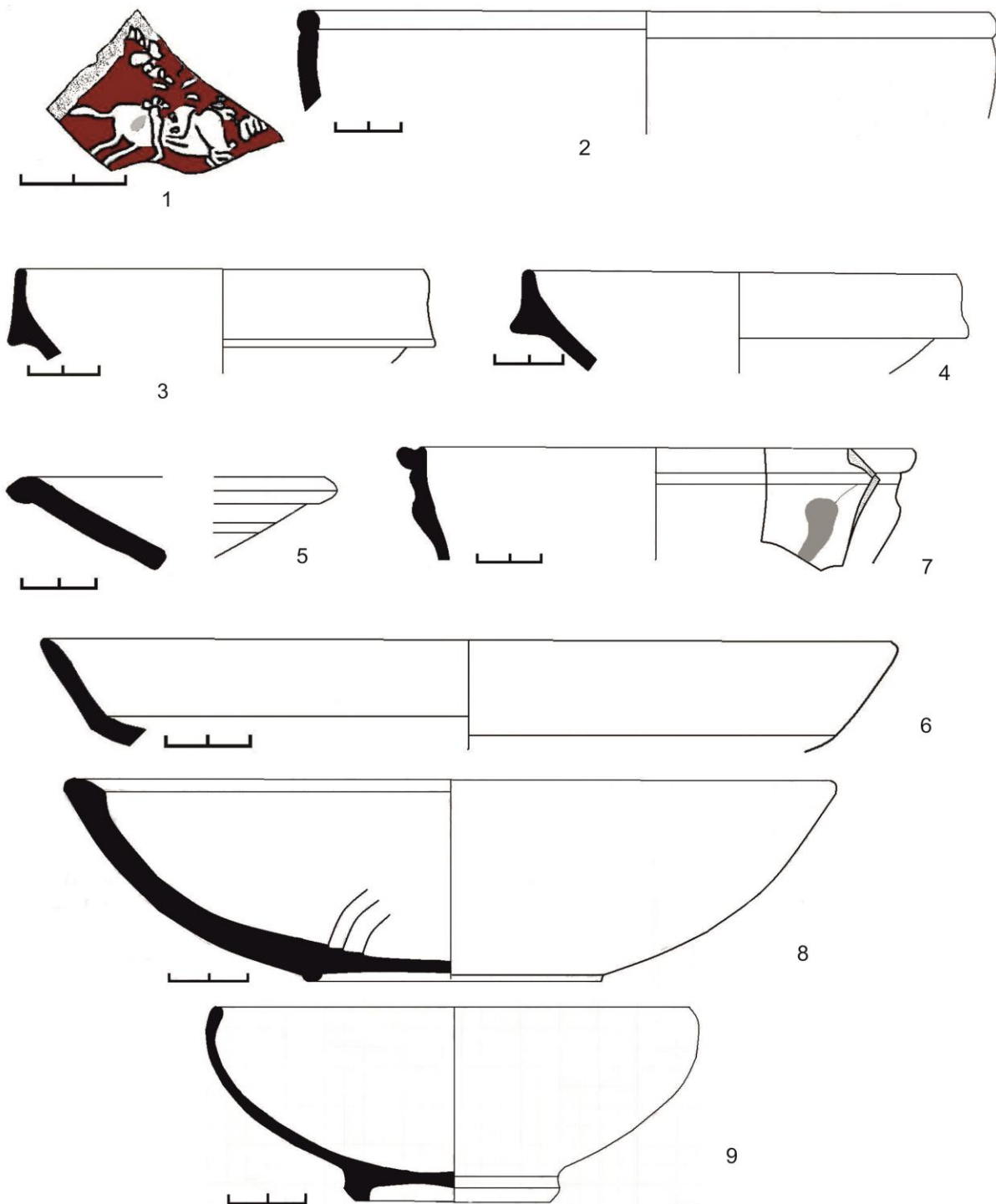

### Pontic pitchers

Simion 2007, fig. 5; Simion 1984, pl. XIV/5; Băjenaru 2013, pl. 6/44, pl. 19/44

22. T6, C3, pitcher, a fragment of the base, p.h.–5 cm, base d.–4 cm, oxidative firing, semi-fine reddish fabric with black particles, slip at the same colour, Munsell 2.5YR 6/8 light. The base has a foot ring;
23. T6, C3, pitcher, a fragment of the base, p.h. 4 cm, base d. 5 cm, oxidative firing, semi-fine reddish fabric with silver mica sparkles and limestone particles, porous, red paint on the outside, Munsell 7.5YR 8/6 reddish yellow, the base has a low foot ring;

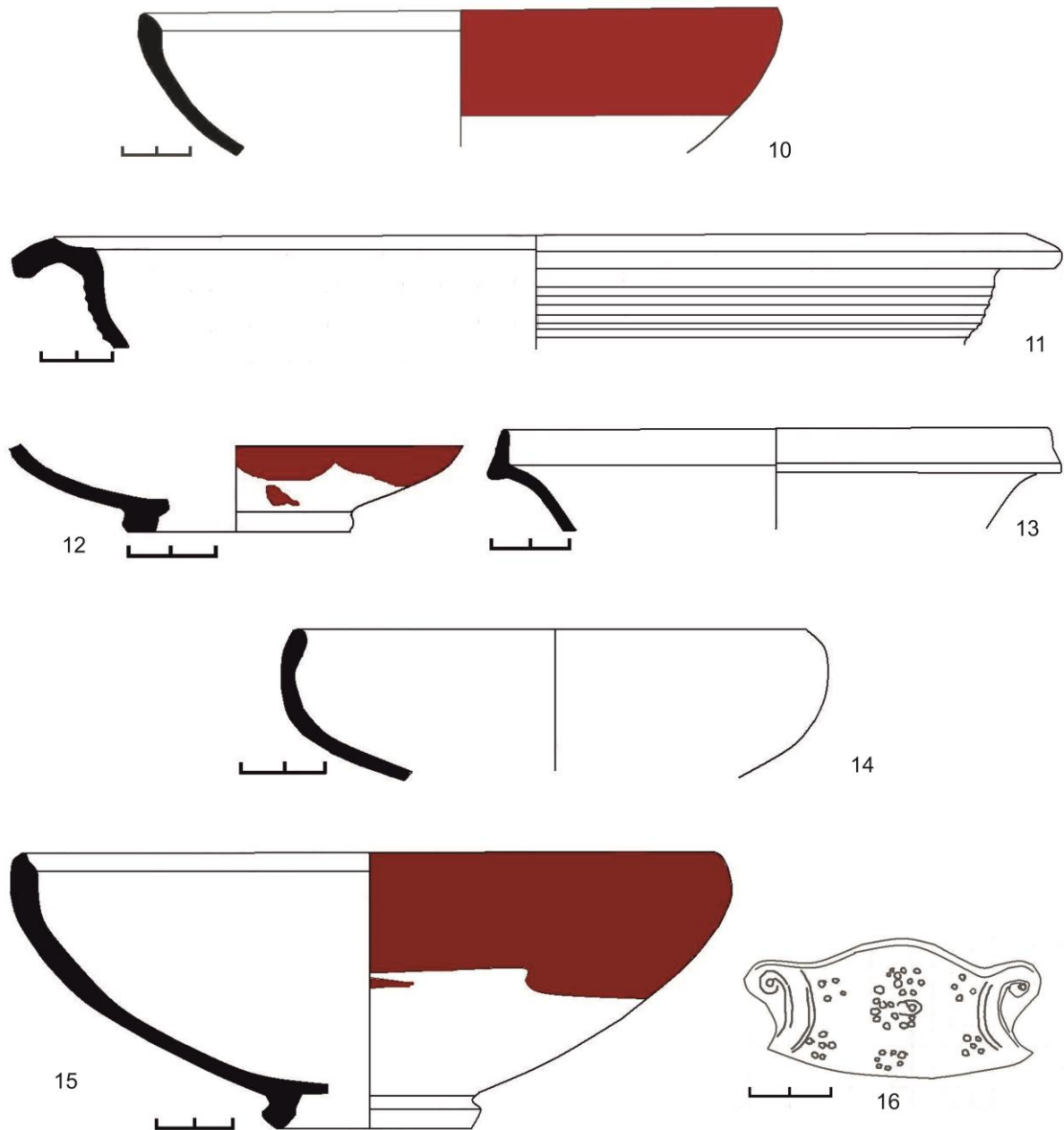

24. T6, C3, pitcher, a fragment of the base, p.h.–2 cm, base d.–4.5 cm, oxidative firing, reddish semi-fine fabric with silver mica sparkles and limestone particles, the core is grey, Munsell 7.5YR 8/6 reddish-yellow. The base has a foot ring;
25. T6, C3, pitcher, a fragment of the upper part, p.h.–6.5 cm, r.d.–5.2 cm, oxidative firing, reddish fabric with limestone particles, slip at the same colour, Munsell 10R 6/8 light red, the rim is thickened outwards, the vessel presents a single grooved decorated, oval in section handle. Simion 1984, pl. XIV/5 (Noviodunum); Simion 2007, fig. 5;



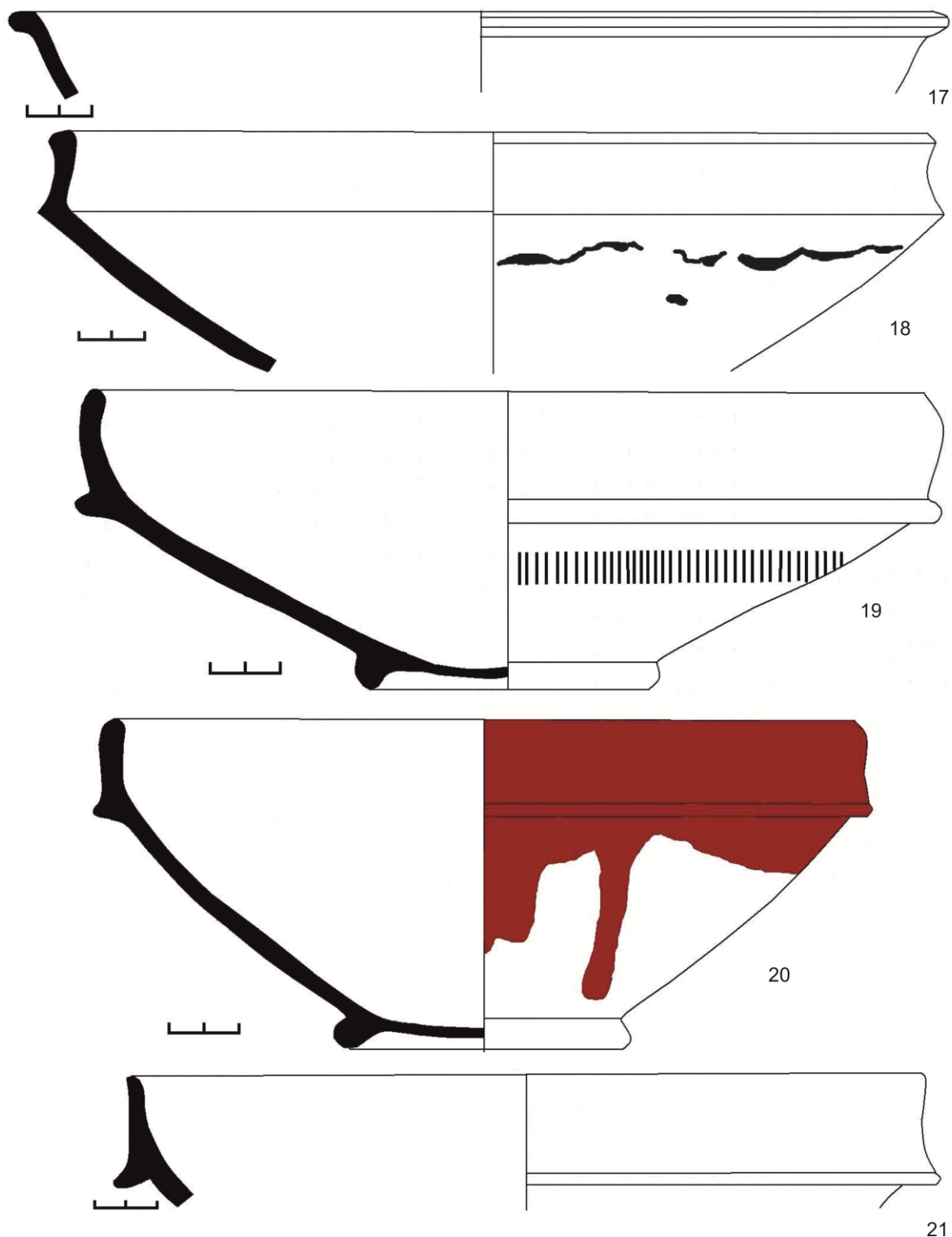

26. T3, C3, pitcher, a fragment of the base, base d.–7 cm, p.h.–11 cm, semi coarse reddish fabric with iron oxide and black microparticles, red paint carelessly applied at the outside Munsell 2.5YR 6/8 light red;

27. T6, C 3, pitcher, a fragment of the base, base d.–9 cm, p.h.–4 cm, semi-fine reddish fabric with white particles in composition, reddish slip, Munsell 2.5YR 6/6 light red;
28. T6, C 3, pitcher, a fragment of the base, base d.–7.5 cm, p.h.–3 cm, brick colour fabric with silver mica and white particles, light brick colour slip, Munsell 7.5YR 8/4 pink;

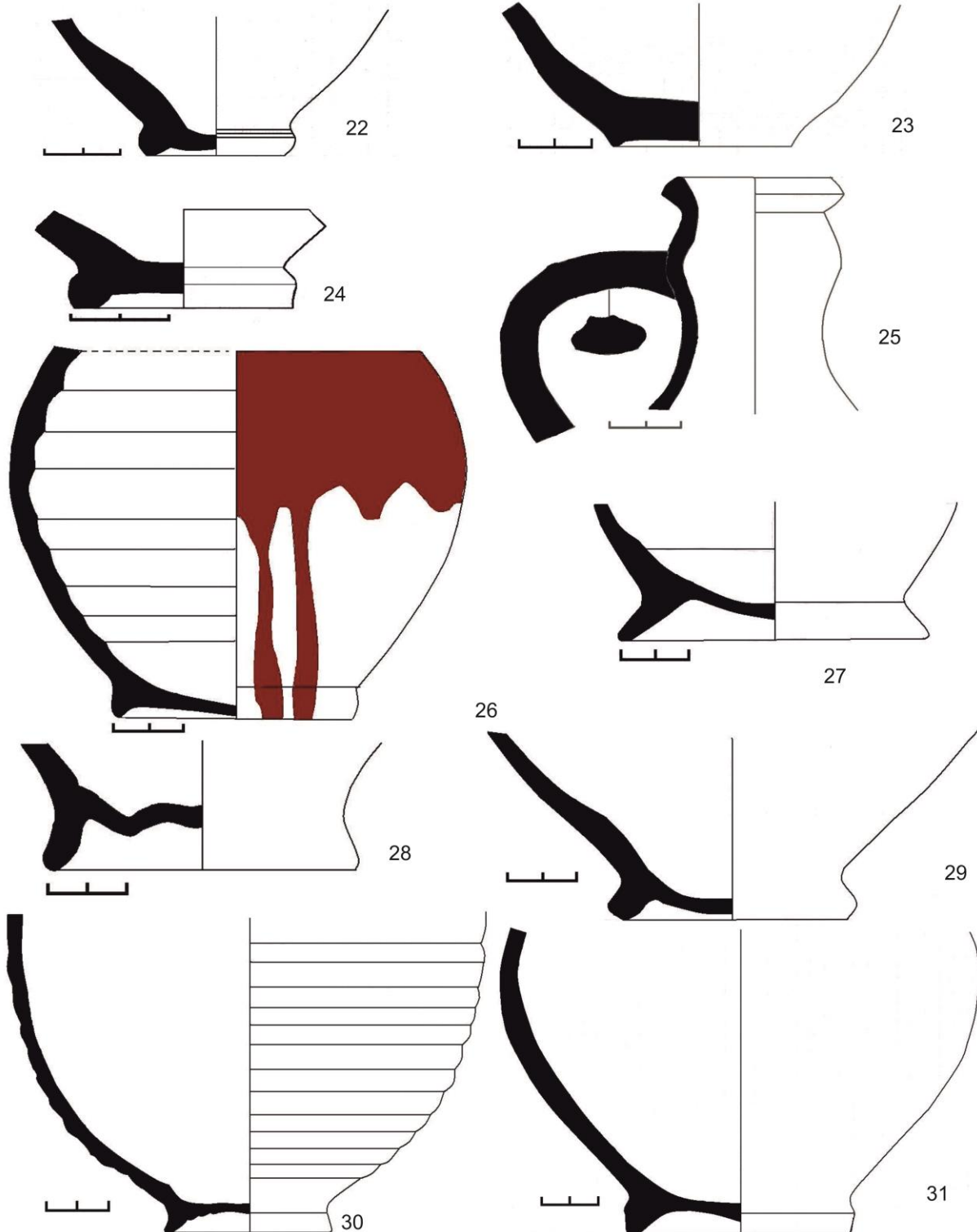

29. T9, C15, pitcher, a fragment of the base, p.h.–5.5 cm, base d.–7.5 cm, semi-fine reddish fabric with rare limestone particles, the core is light grey, secondarily fired at the outside, Munsell 10YR 7/6 yellow;
30. T3, pitcher, a fragment of the base, p.h.–10 cm, base d.–5.5 cm, semi-fine, reddish fabric with limestone particles, red painting at the inside, reddish-yellow slip at the outside, traces of mortar at the inside, Munsell 5YR 6/6 reddish-yellow. Foot ring-shaped, grooves on the body;

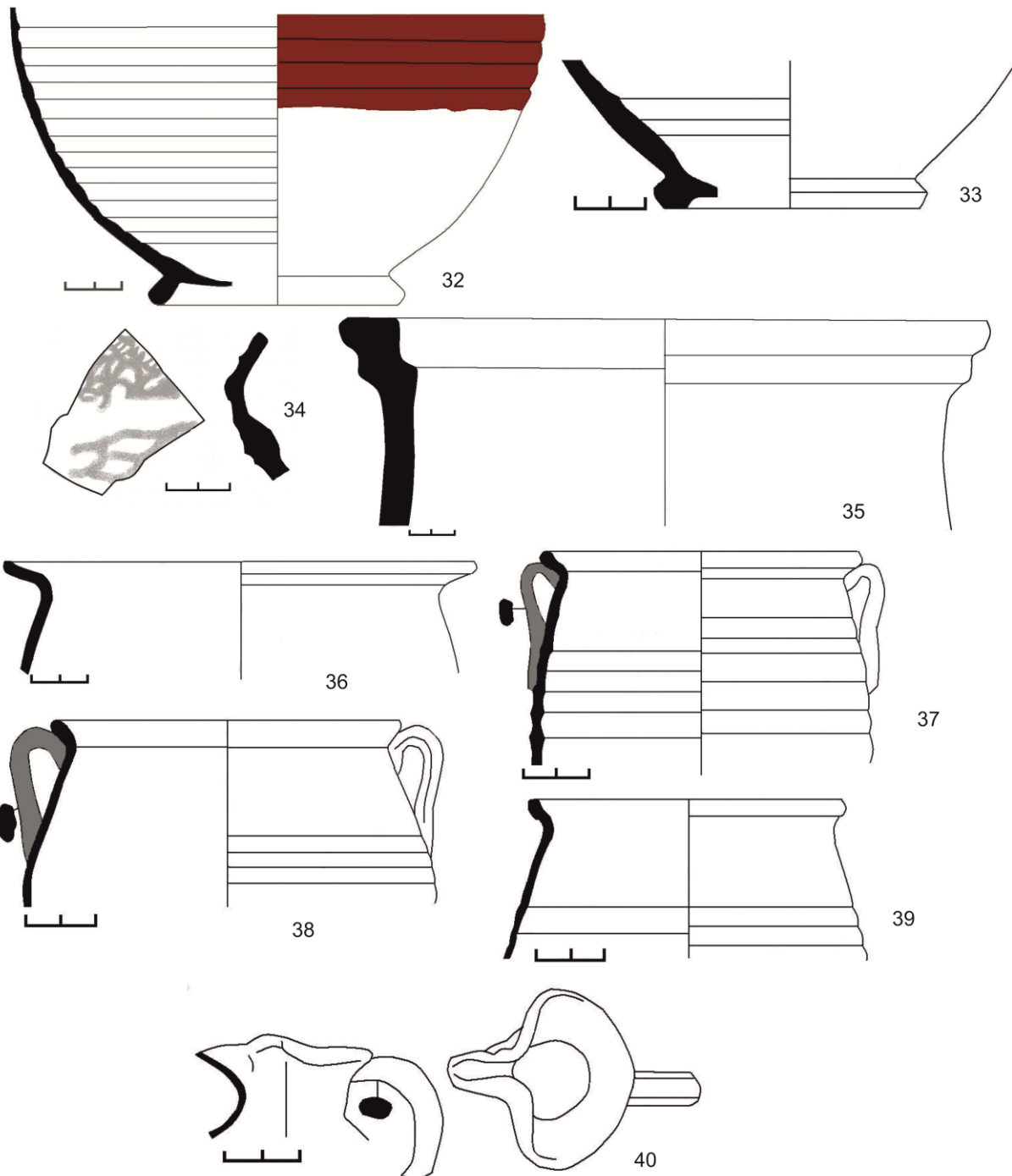

31. T6, C3, pitcher, a fragment of median part and base, base d.–8 cm, p.h.–10,5 cm, semi-fine reddish colour fabric limestone particles in composition, traces of dark red paint on the inside and outside Munsell 7.5TR 8/6 reddish-yellow. Ring – foot;
32. T6, C3 pitcher, a fragment of base and median part, base d.–8,5 cm, p.h.–10 cm, fine, reddish fabric with silver mica, red paint at the outside, Munsell 7.5YR 8/6 reddish-yellow. Grooves at the inside and partially at the outside, ring – foot;
33. T5, C3, pitcher, a fragment of the base, base d.–7 cm, p.h.–4 cm, semi-fine reddish fabric with rare microparticles of limestone, traces or mortar at the inside, Munsell 7.5YR 8/6 reddish yellow.

#### Other possibly Pontic types

34. T9, C1, fine vessel, fragment, p.h.–5 cm, p. length–6 cm, oxidative firing, fine reddish fabric, traces of red/brown paint at the outside and partially at the inside, Munsell 2.5YR 6/8 light red. The vessel was decorated with (probably animally) stamped figures. Possibly the fragment came from a Roman vessel in the shape of a ram/*askos*;
35. T5-T6, C1, a fragment of the rim, r.d.–28 cm, p.h.–9 cm, coarse reddish fabric with sand and iron oxide, red slip, Munsell 2.5YR 7/8 light red. Possibly a flagon/big jug. Ciușescu, Mustața 2007, pl. XIII/1-4 (Roman Dacia, flagon, 2<sup>nd</sup>-3<sup>rd</sup> c AD);

#### AEGEAN DRINKING WARES (MUGS & JUGS/PITCHERS)

The walls of the wares are unusually thin, hard fabric, containing possibly volcanic inclusions. Nagy 2016

36. T6, C3, mug, a fragment of the rim, r.d.–16 cm, p.h.–3.8 cm, oxidative firing, pink semi-fine fabric with rare particles of limestone, severely secondarily fired at the outside. The fabric colour is Munsell 7.5 YR 7/6 reddish-yellow. Slip color Munsell 1 for Gley 2.5/1 greenish-black;
37. T6, C3, mug, a fragment of the upper and median part, r.d.–10 cm, p.h.–6.5 cm, fine, reddish colour fabric with rare micro particles of limestone, greyish slip at the outside. The colour of the outside coating is Munsell 7.5 YR 6/4 light brown. The colour of the fabric is Munsell 7.5YR 7/8 reddish-yellow. The rim is thickened, reversed to the outside and the body is decorated with grooves; the handles are oval in section;
38. T6, C3, mug, a fragment of the upper and median part, p.h.–5.5 cm, r.d.–10 cm, fine reddish fabric with limestone particles in composition, self-slip, Munsell 7.5YR 8/6 reddish-yellow. The median part is decorated with grooves; the handles are oval in section;
39. T6, C3, mug, a fragment of the median and upper part, r.d.–9 cm, p.h.–4.5 cm, fine reddish fabric, brown exterior slip, secondarily fired at the outside. Colour of the fabric is Munsell 7.5YR 8/6 reddish yellow, and the slip colour is 7.5YR 7/4 pink;
40. T6, C3, trefoil - mouthed jug, a fragment of the upper part, r.d.–4.5 cm, p.h.–2.5 cm, fine, reddish fabric, reddish-grey slip at the outside and partially at the inside, Munsell (slip) 7.5YR 7/3 pink, and the fabric 7.5YR 8/6 reddish-yellow. Trilobite rim, oval handle in section. Băjenaru 2013, (cruches à embouchures trilobée – production de Thrace égéenne) p. 57-58, pl. 7/48-50, pl. 20/48, 49, 50, (Tomis). Close similarity with Collarino type mugs;
41. T6, C3, mug, 2 fragments (not joining) of upper and medium part, r.d.–9.5 cm, p.h.–7 cm, maximum d. 12 cm, fine, reddish fabric, reddish-grey slip at the exterior and interior

of the vessel. Munsell colour of the slip is 7.5YR 7/3 pink, and the fabric is 7.5YR 8/6 reddish-yellow. Grooves at the medium part, no handles preserved;

42. T6, C3, mug, a fragment of the rim, p.h.–2,5 cm, r.d.–9 cm, semi-fine brownish fabric, reddish-grey surface treatment at the inside and outside, Munsell fabric colour is 5YR 6/8 reddish yellow and the slip colour is 7.5 YR 7/3 pink;

#### COOKING WARES. PONTIC, AEGEAN TYPES & IMPORTS, SOME OF THEM UNCLASSIFIED

##### Pans

**Honcu 2017, pans type II, p. 93-96, pl. XVII-XIX/175-191 (2<sup>nd</sup>-3<sup>rd</sup> c. AD), pans type III, pl. XIX/182;**

Flat rim decorated with a groove; the body is sometimes slightly carinated. Common Roman provincial type.

43. T5-T6, C1, pan, a fragment of the rim, r.d.–34 cm, p.h.–4.5 cm, semi coarse, reddish fabric with sand and limestone porous, Munsell 2.5Y 8/4 pale yellow. Dark reddish-grey slip at the inside, Munsell 2.5Y 7/2 light grey;
44. T6, C3, pan, fragment, h.–5 cm, r.d.–32 cm, base d.–18 cm, coarse reddish fabric with sand and limestone in composition, secondarily fired at the outside and inside, Munsell 7.5 YR 6/8 reddish-yellow. The base is flat, almost horizontal flat rim that has a lid-seating on the top;
45. T6, C3, pan, a fragment of the upper part, r.d.–34 cm, p.h.–5.2 cm, oxidative firing, brick colour coarse fabric with limestone and sand in composition, secondarily fired at the outside, Munsell 5YR 6/8 reddish-yellow. Carinated body. The flat rim has a lid-seating on the top;
46. T6, C3, pan, a fragment of the rim, r.d.–28 cm, p.h.–4 cm, oxidative firing, coarse brick colour fabric with sand and limestone in composition, secondarily fired at the outside, Munsell 7.5YR 8/6 reddish-yellow. The flat rim has a lid-seating on the top.

##### Variants

47. T1, C1, pan, a fragment of the rim r.d.–23 cm, h.–4,5 cm, oxidative firing, reddish coarse fabric with limestone and black particles in composition, secondarily fired at the outside and partially at the inside, Munsell 7.5YR 7/4 pink. The rim has a lid-seating on the top. At the level of the rim, the pan is presenting a small, poor preserved flat handle. Possibly Aegean import. Istenic, Schneider 2000, fig 5/3;
48. T6, C3, pan, a fragment of the rim and upper part, r.d.–36 cm, p.h.–4,5 cm, oxidative firing, semi coarse, reddish, porous fabric with silver mica, sand and black and white particles in composition, black painting at the inside, Munsell 10YR 2/1 black. The core is whitish – grey, flat rim. Probably imported from another area. The black painting makes more difficult the identification of the producer area. The form is not uncommon: Honcu 2017, pans type II, 95, pl. XVIII/175 (Noviodunum).

**Honcu 2017, bowls type VIII, p. 115, pl. XXIV/237 (3<sup>rd</sup> c. AD)**

The rim is flat, decorated with concentric grooves at the top. The form is common for Roman provincial production, and we see no reason that this type not to be produced in the West Pontic region.

49. T1, C1, pan, a fragment of the rim, r.d.–26 cm, p.h.–3 cm, oxidative firing, coarse yellowish fabric with limestone particles, yellow slip, secondarily fired at the outside, concentric grooves at the top of the rim, Munsell 10YR 8/3 very pale brown;
50. T1, C1, pan, a fragment of the upper part, r.d.–22 cm, p.h.–2.5 cm, whitish coarse fabric with sand in composition, secondarily fired at the outside, Munsell 2.5Y 8/3 pale yellow. Flat rim, decorated with concentric circles on the superior part.

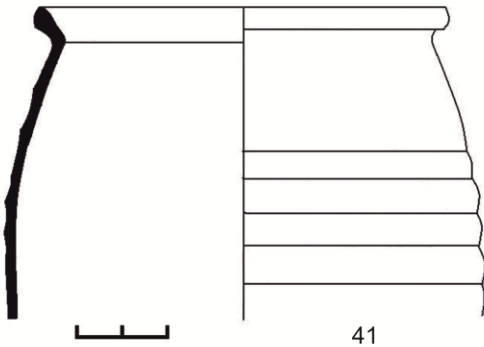

41

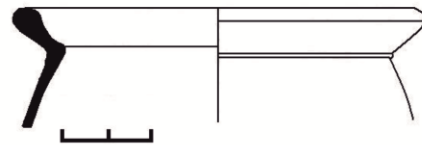

42

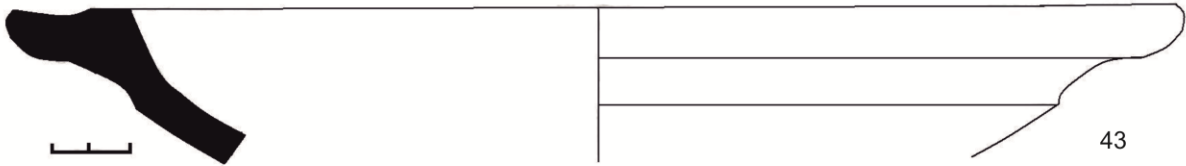

43

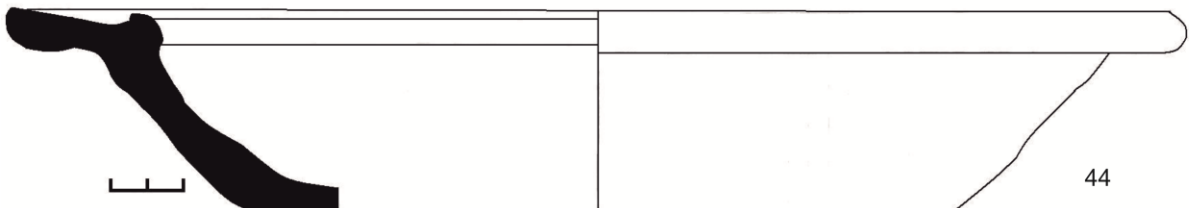

44

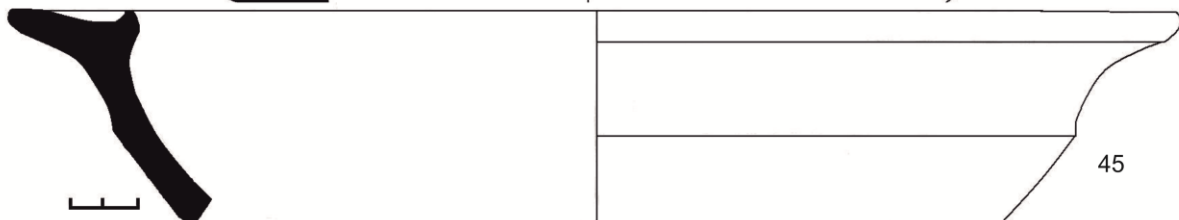

45

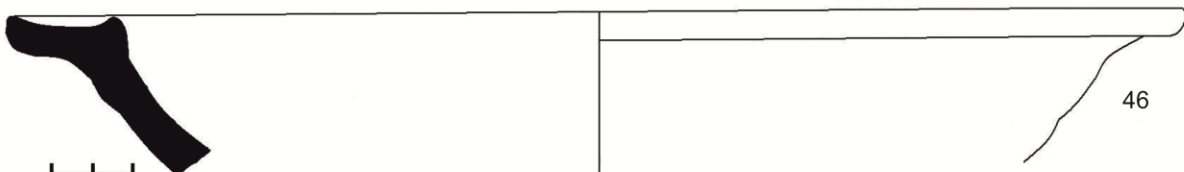

46

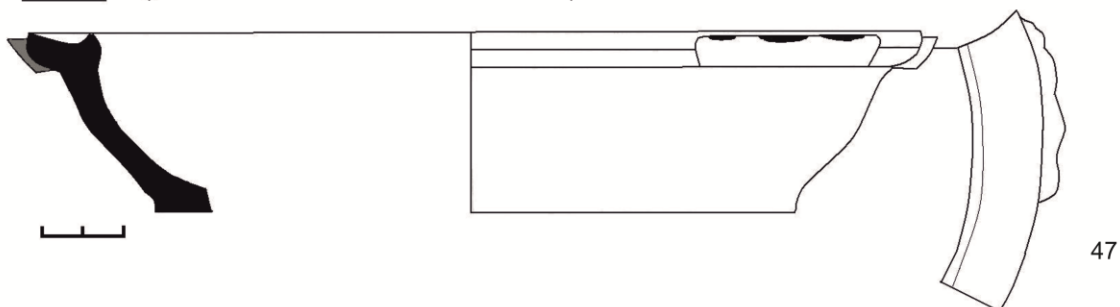

47

**Other pans, having probably Pontic origins.**

51. T6, C3, pan or tray, fragment, maximum d.–35 cm, h.–5.5 cm, semi coarse light reddish fabric with red particles and black mica, secondarily fired on the outside, Munsell 10 YR 8/4 very pale brown. Honcu 2017, pans type IV, 98, pl. XIX/186-187 (Durostorum), 2<sup>nd</sup>-3<sup>rd</sup> c. AD.;
52. T6, C3, pan, fragment, r.d.–28 cm, p.h.–7 cm, oxidative firing, red-brick colour coarse fabric with limestone and sand particles, coated, secondarily burned at the outside, Munsell 7.5YR 8/6 reddish-yellow. The rim is flattened, the body is concave and the base is flat. Honcu 2017, bowls type I, 107, 2<sup>nd</sup>-3<sup>rd</sup> c AD, pl. XXII/212 (Durostorum);
53. T1, C1, pan, a fragment of the rim, r.d.–28 cm, p.h.–5,5 cm, brick color coarse fabric with sand, secondarily fired at the outside, Munsell 7.5YR 7/8 reddish yellow (fabric), and Munsell 5YR 2.5/2 dark reddish-brown (slip). Băjenaru 2013, p. 67, pl. 11/89 (Tomis); Honcu 2017, pans type II, pl. XIX/179 (Noviodunum);
54. T5-T6, C1, pan, a fragment of the rim, r.d.–32 cm, p.h.–5,5 cm, coarse reddish fabric with sand and limestone particles in composition, red slip at the inside, secondarily fired at the outside, Munsell 2.5YR 6/8 light red. Honcu 2017, pans type II, pl. XVIII/171;
55. T1, C1 pan, a fragment of rim and median part, r.d.–24 cm, p.h.–4 cm, whitish coarse fabric with sand and limestone particles in composition, Munsell 2.5YR 8/3 pale yellow. Flat rim, decorated with a groove, carinated body. Topoleanu *et alii* 2014, Pl. V/33 (Noviodunum).

**CASSEROLES**

**Opaiț 1980, pl. II/3. 2<sup>nd</sup>-3<sup>rd</sup> c. AD (Troesmis); Negru, Streinu, 2016, p. 50, pl. 51/3004 (3<sup>rd</sup> c. AD, Romula). A common form, possibly West Pontic.**

The rim is flat and thickened to outside, the body is slightly curved, flat base, there are usually grooves on the body of the vessel, and flat, presenting grooves handle in section.

56. T9, C15, casserole, a fragment of the upper part, r.d.–28 cm, p.h.–4.5 cm, pale grey coarse fabric with sand in composition, secondarily fired at the outside, cream-coloured coating at the inside, Munsell 2.5Y 8/3 pale yellow. The rim is flat and thickened to the outside;
57. T6, C3, casserole, fragmentary, h.–15 cm, r.d. 28 cm, base d.–8.5 cm, oxidative firing, semi coarse yellowish fabric with limestone particles, silver mica and fine sand, yellow colour coating, secondarily fired at the outside, Munsell 5Y 8/2 pale yellow. Flat rim; funnel-shaped neck, the flattened handles and body decorated with grooves, flat base.

**Ožanić Roguljić 2008, fig. 4, CPB2 (*Cibalae*, end of 1<sup>st</sup>-2<sup>nd</sup> c. AD); Honcu 2017, bowls type I, 106, pl. XXII/209-213 (2<sup>nd</sup>-3<sup>rd</sup> c. AD).**

58. T 6, C3, casserole, a fragment of the rim, p.h.–6 cm, r.d.–28 cm, oxidative firing, coarse clay with limestone particles, Munsell 10 R 6/8 light red, and the rim is flat presenting a groove on the top on the inside, concave body;
59. T6, C3, casserole, a fragment of the upper and median part, r.d.–26 cm, p.h.–6 cm, oxidative firing, red coarse fabric with sand and limestone particles, secondarily burned at the outside, red-coated, Munsell 2.5YR 6/8 light red. The rim is flatted; the body of the vessel is concave.

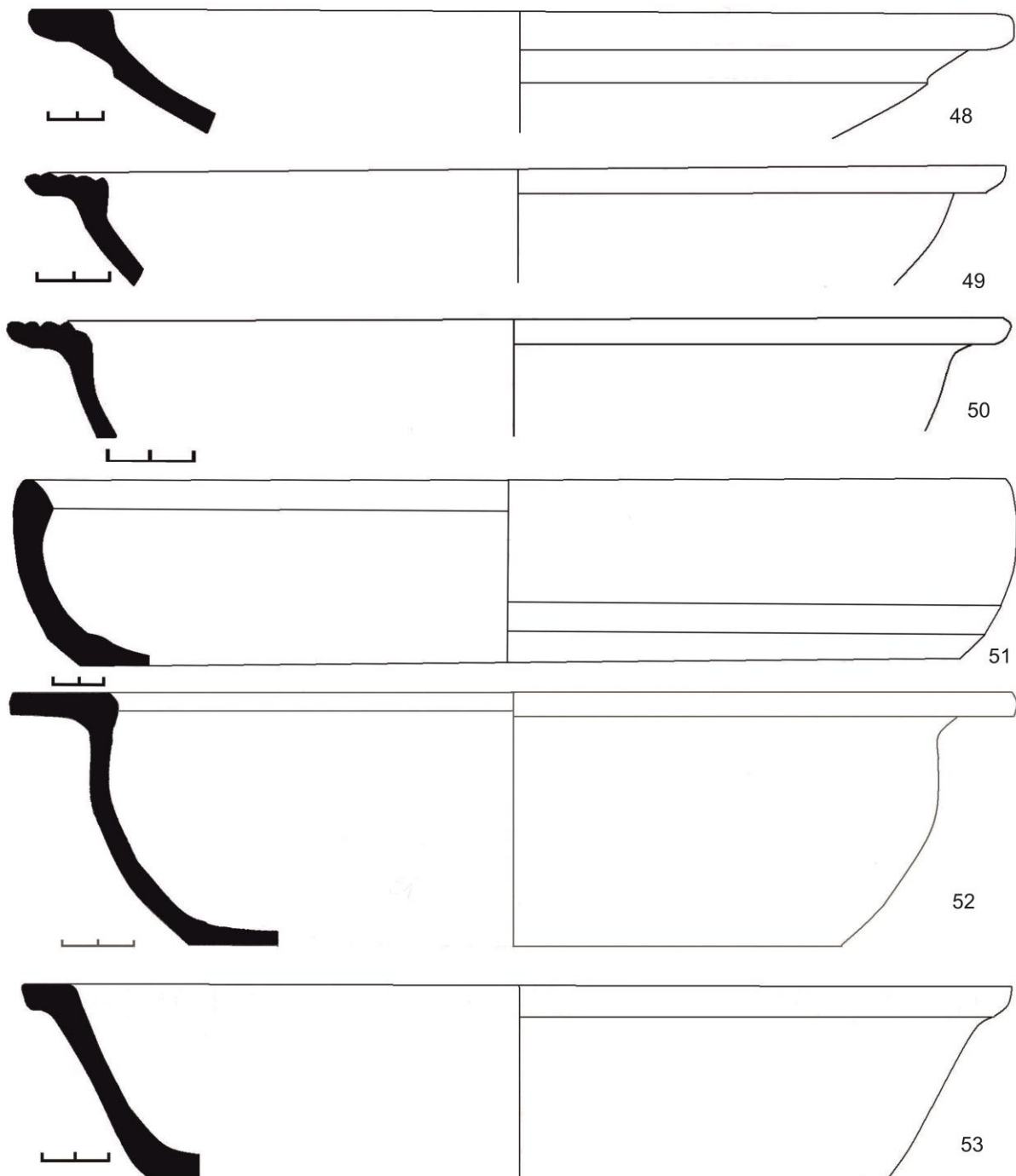

Honcu 2017, bowls type IV, 110-111, pl. XXIII/222, 2<sup>nd</sup> c. AD; Negru, Streinu 2016, pl. 53/1881, 2549 (Romula)

The rim is reverted to inside, resembling some Roman pot types, but the curvature of the preserved wall is too pronounced at the median part to be a potshard part. Also, the rim diameter of 30 cm in both cases and the coarse fabric, specific to the cooking ware, qualify these examples, despite the lack of perfect analogies, in the functional category of casseroles. Both examples are secondarily fired on the outside being used on the open fire.



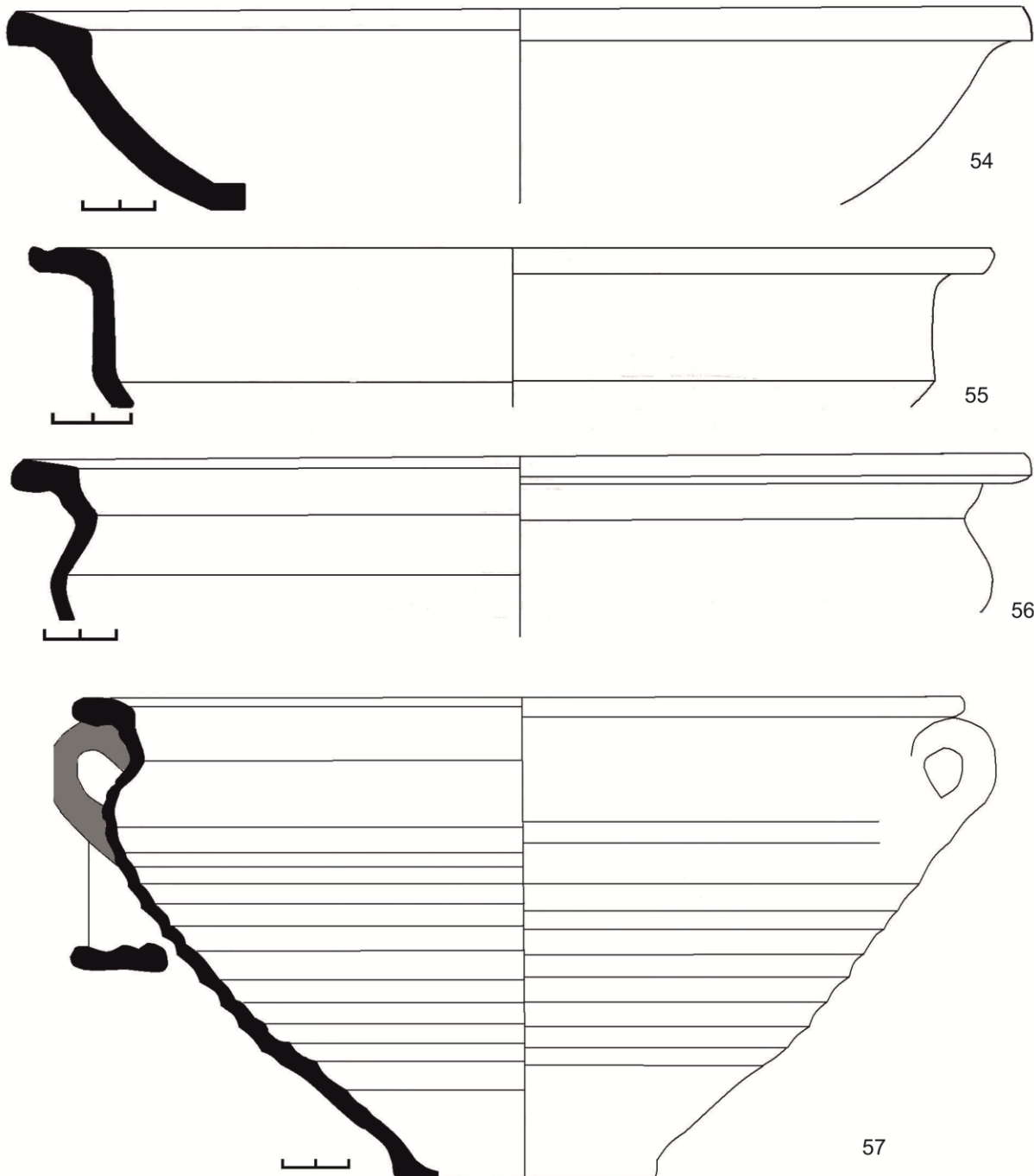

60. T1, C1, casserole, fragment of rim, r.d.–30 cm, p.h.–5 cm, pale yellowish coarse fabric with fine sand and small stones in composition, secondarily fired at the outside, Munsell 5Y8/4 pale yellow.
61. T1, C1, casserole, a fragment of the rim and median part, r.d.–30 cm, p.h.–4.5 cm, whitish coarse fabric with sand in composition, secondarily fired at the outside, Munsell 2.5Y 8/3 pale yellow, the rim is reverted to the interior, the body is carinated, decorated with one groove.

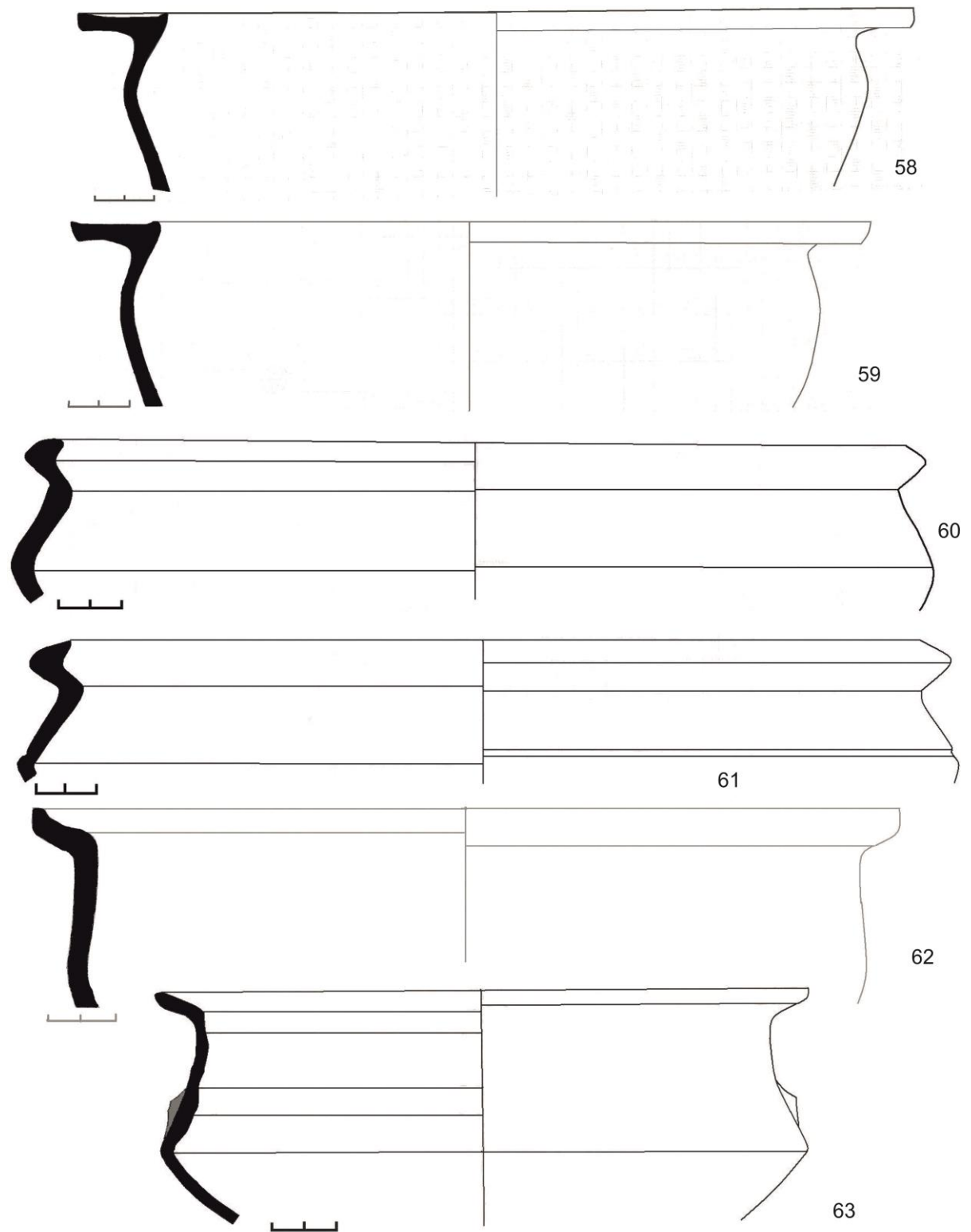

**Opaïț 1980, pl. III/2, p. 330, 351 Troesmis, end of the 2<sup>nd</sup> c. AD, microasiatic origin of the form. Honcu 2017, casseroles type II, p. 84, pl. XVI-XVI, Aegean area. 2<sup>nd</sup>-3<sup>rd</sup> c. AD. Istenic, Schneider 2000, fig 5/3. Aegean area.**

The rim is flat, slightly curved to the inside, the body is bitruncated. All exemplars present handles, oval decorated in section and grooved.

62. T6, C3, casserole, a fragment of the upper and median part, r.d.–26 cm, p.h.–6 cm, oxidative firing, coarse reddish fabric with sand and limestone particles, slip at the same colour, secondarily burned at the outside, Munsell 2.5YR 6/8 light red. The rim is flattened, presenting a concavity for the lid, traces of a missing handle. Honcu 2017, pl. XIV/141, casseroles type 2, (Ibida, the first half of the 2<sup>nd</sup> c. AD);
63. T6, C3, h-0,80 m, the first layer of filling of the pit, casserole, fragment upper and median part, r.d.–20 cm, p.h.–7 cm, oxidative firing, semi-fine, dark brick colour fabric with silver mica and limestone particles, secondarily fired at the outside, Munsell 10 YR 7/8 yellow. The rim is flat, slightly curved to the inside, bitronconic body, traces of handles;
64. T1, C1, casserole, fragment of upper part, r.d.–20 cm, p.h.–5.5 cm, oxidative firing, semi-fine, reddish colour fabric with limestone particles and silver mica sparkles, slip at the same colour, secondarily fired at the outside, Munsell 2.5YR 6/8 light red. The handle is oval in section and decorated with grooves, the rim is almost flat;
65. T6, C3, casserole, a fragment of the upper part, r.d.–22 cm, p.h.–6.5 cm, semi-fine reddish colour fabric with rare limestone particles, self-slip, secondarily fired at the outside, Munsell 7.5YR 7/6 reddish-yellow. The rim is flat, slightly inclined to the inside;
66. T6, C3, casserole, a fragment of the upper part, r.d.–18 cm, p.h.–5.5 cm, semi-fine brick colour fabric with rare limestone particles, secondarily fired, traces of handle, Munsell 7.5YR7/6 reddish-yellow. The rim is flat, slightly inclined to the inside;
67. T6, C3, casserole, a fragment of the upper part, r.d.–16 cm, p.h. 6.5 cm, brick colour semi-fine fabric with rare limestone particles, self-slip, secondarily fired at the outside, Munsell 7.5 YR 7/6 reddish-yellow. The rim is flat, slightly inclined to the inside;
68. T6, C3, casserole, a fragment of the upper part, r.d.–24 cm, p.h.–6.5 cm, semi-fine reddish fabric with limestone particles and fine sand in composition, secondarily fired at the outside, self-slip at the inside, greyish slip at the outside, Munsell 10R 5/8 red. Carinated body, flattened rim, oval handles in section;
69. T6, C3, pot, a fragment of the upper part, r.d.–15 cm, p.h.–3.5 cm, pink semi-fine fabric with rare limestone particles in composition, self-slip, secondarily fired at the outside, reddish-grey slip at the outside, Munsell 2.5YR 6/8 light red. The rim is flattened, slightly reverted to the outside, globular body, oval handles in section.

**Mușețeanu, Elefterescu 2004, p. 120, pl. XI/1-2 (Durostorum, 2<sup>nd</sup>-3<sup>rd</sup> c. AD); Opaïț 1980 pl. II/1, 2, 5. Negru, Streinu 2016, pl. 53/3781 (Romula); Honcu 2017, p. 116, pl. XXV/239, bowls type IX, 2<sup>nd</sup>-3<sup>rd</sup> c. AD.**

The casserole presents a bitronconic body, with or without handles and a (probably) flat base. The first example presents a groove at the top of the lip while the second example is decorated with marked grooves at the main body and has a simple rim. Both examples may be dated during the 2<sup>nd</sup>-3<sup>rd</sup> c. AD

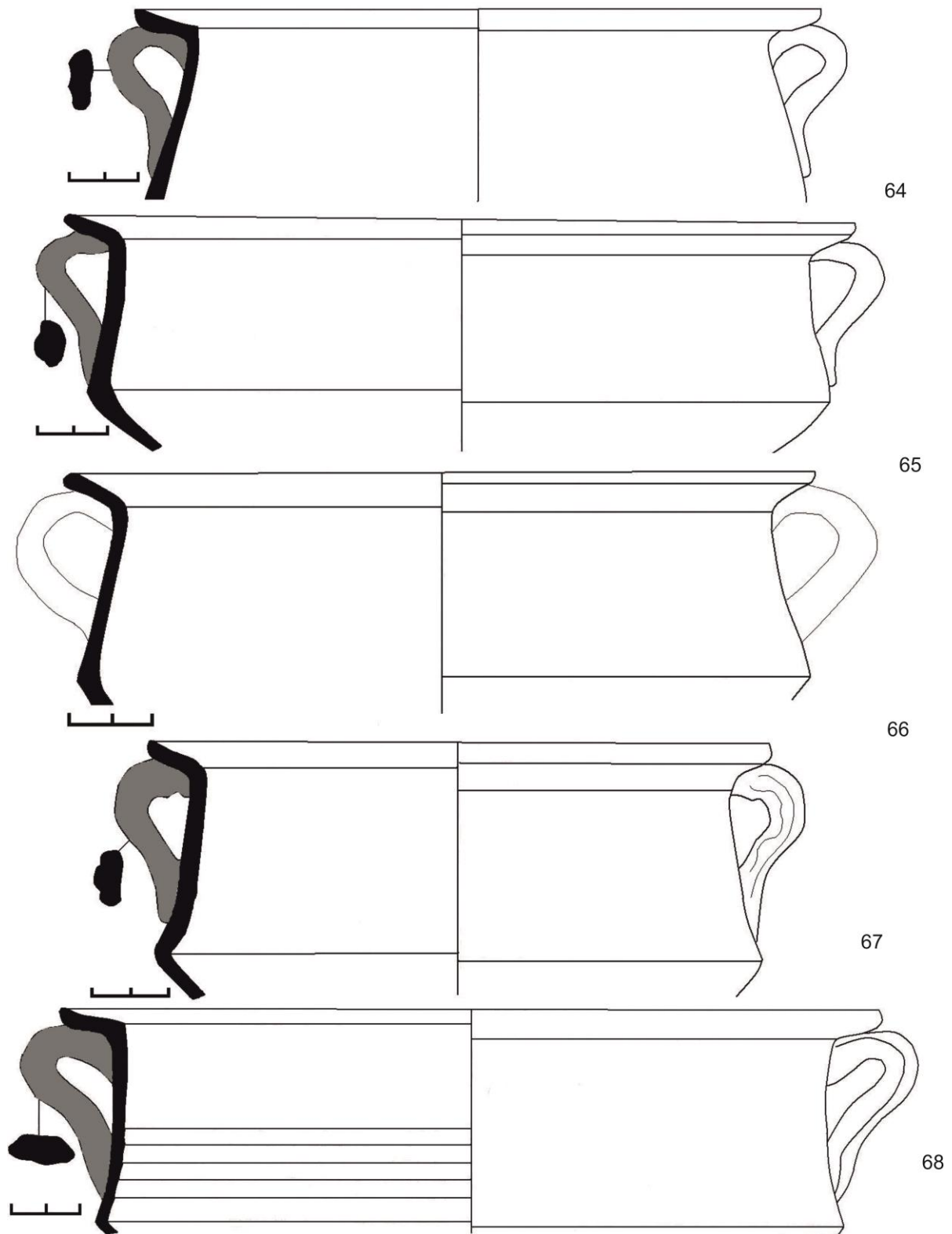

- 70.** T1, C1, casserole, fragment of rim, r.d.–22 cm, p.h.–5.5 cm, pale yellow coarse fabric with sand in composition, secondarily fired at the outside, Munsell 10 YR 8/3 very pale brown;

71. T1, C1, casserole, a fragment of the rim, r.d.–20 cm, p.h.–8 cm, coarse pale yellow fabric with sand and red particles, secondarily fired at the outside, Munsell 5Y 8/3 pale yellow;

#### Pots

**Honcu 2017, pots type XIV, p. 67, pl. IX/86 (2<sup>nd</sup>-3<sup>rd</sup> c. AD, “Levantine origin”); Băjenaru 2013, p. 66, pl. 10/81 (Tomis); Opaïț 2004, pots type VII, p. 47 (Tomis, 4<sup>th</sup> c. AD, imported)**

The rim is presenting a notch at the upper outside part of the lip, a vertical neck sustaining the concave rim and a globular body.

72. T6, C3, pot, a fragment of the upper part, p.h.–10 cm, r.d.–25 cm, reducing firing, coarse gray fabric with sand and small stones, roughly modelled on the wheel, secondarily fired at the inside and outside, Munsell 2.5YR 6/3 light reddish-grey.

**Honcu 2017 imported pots type II, 77-78, pl. XII/119-120 (2<sup>nd</sup>-3<sup>rd</sup> c. AD, Aegean); Honcu 2017 pots type XVI, 68, pl. IX/89 (1<sup>st</sup>-2<sup>nd</sup> c. AD); Băjenaru 2013, pots type 1, 61, pl. 8/60-61 (production égéenne 1<sup>st</sup>-2<sup>nd</sup> c. AD Tomis)**

The rim of the pot is flat, bent to the outside, globular body.

73. T6, C3, pot, a fragment of the rim, p.h.–5 cm, r.d.–20 cm, oxidative firing, semi coarse orange fabric with fine sand and limestone in composition, secondarily fired at the outside, Munsell 10 YR 7/8 yellow. The rim is flat and thickened to the outside;
74. T1, C1, pot, a fragment of the rim, p.h.–3 cm, r.d.–16 cm, semi-fine brick colour fabric with iron oxide in composition, brownish slip at the inside and outside, secondarily fired at the outside, Munsell 7,5YR 7/3 pink;
75. T6, C3, pot, a fragment of the rim, r.d. 18 cm, p.h. 2,5 cm, semi-fine, brick colour fabric with rare limestone particles, secondarily fired at the inside and outside, Munsell 1 for Gley 2.5 /black. The rim is simple, reverted to the outside.

**Robinson 1959, G 193; Istenic, Schneider 2000, fig. 2-3 (Aegean); Więch 2017, pl. 6/13 (Aegean); Honcu 2017 imported pots type III, 78, pl. XIII/121-122 (2<sup>nd</sup>-3<sup>rd</sup> c. AD, Aegean); Băjenaru 2013, pots type 2, 61-62, pl. 8/62-63 (production égéenne 2<sup>nd</sup>-3<sup>rd</sup> c. AD Tomis)**

The rim is flat, slightly bent to inside, globular body decorated with grooves. Some examples present handles oval in section.

76. T6, C3, pot, a fragment of the upper part, r.d.–14 cm, p.h.–4 cm, oxidative firing, semi-fine reddish fabric with limestone particles, red slip at the inside and outside, Munsell 2.5YR 6/8 light red. The rim is reverted to the outside; the handles are decorated with grooves, oval in section;
77. T1, C1, pot, a fragment of the upper part, r.d.–14 cm, p.h.–4 cm, oxidative firing, semi-fine reddish fabric with sand in composition, reddish coating, secondarily fired at the outside, Munsell 5YR 7/8 reddish yellow, oval handle in section;
78. T6, C3, pot, a fragment of the upper part, r.d.–19 cm, p.h.–7,5 cm, oxidative firing, semi-fine reddish fabric with rare limestone particles, secondarily fired at the outside and inside, Munsell 5YR 7/6 reddish-yellow. Oval handle in section, grooves on the median part of the vessel;
79. T6, C3, single handle pot, a fragment of the upper part, r.d.–16 cm, p.h.–6.5 cm, oxidative firing, semi-fine, brick colour fabric with rare limestone particles in composition, slip at the same colour, secondarily fired at the outside and partially at the

inside, Munsell 5YR 7/8 reddish-yellow. The rim is flat, slightly inclined to the inside; grooves on the median part, the handle is oval in shape, decorated with grooves;

**80.** T6, C3, pot, a fragment of the upper part, r.d.–17 cm, p.h.–4.5 cm, semi-fine reddish fabric with rare microparticles of limestone in composition, secondarily fired at the outside, greyish slip at the outside, Munsell 10R 4/8 red. Oval handles in profile;

**81.** T6, C3, pot, a fragment of the upper part, r.d.–20 cm, p.h.–7 cm, semi-fine, brown fabric with rare microparticles of limestone, self-slip at the inside and reddish/grey at the outside, secondarily fired at the outside, Munsell 10R 5/6 red. The rim is flatted, oval handles in section, grooves at the median part;

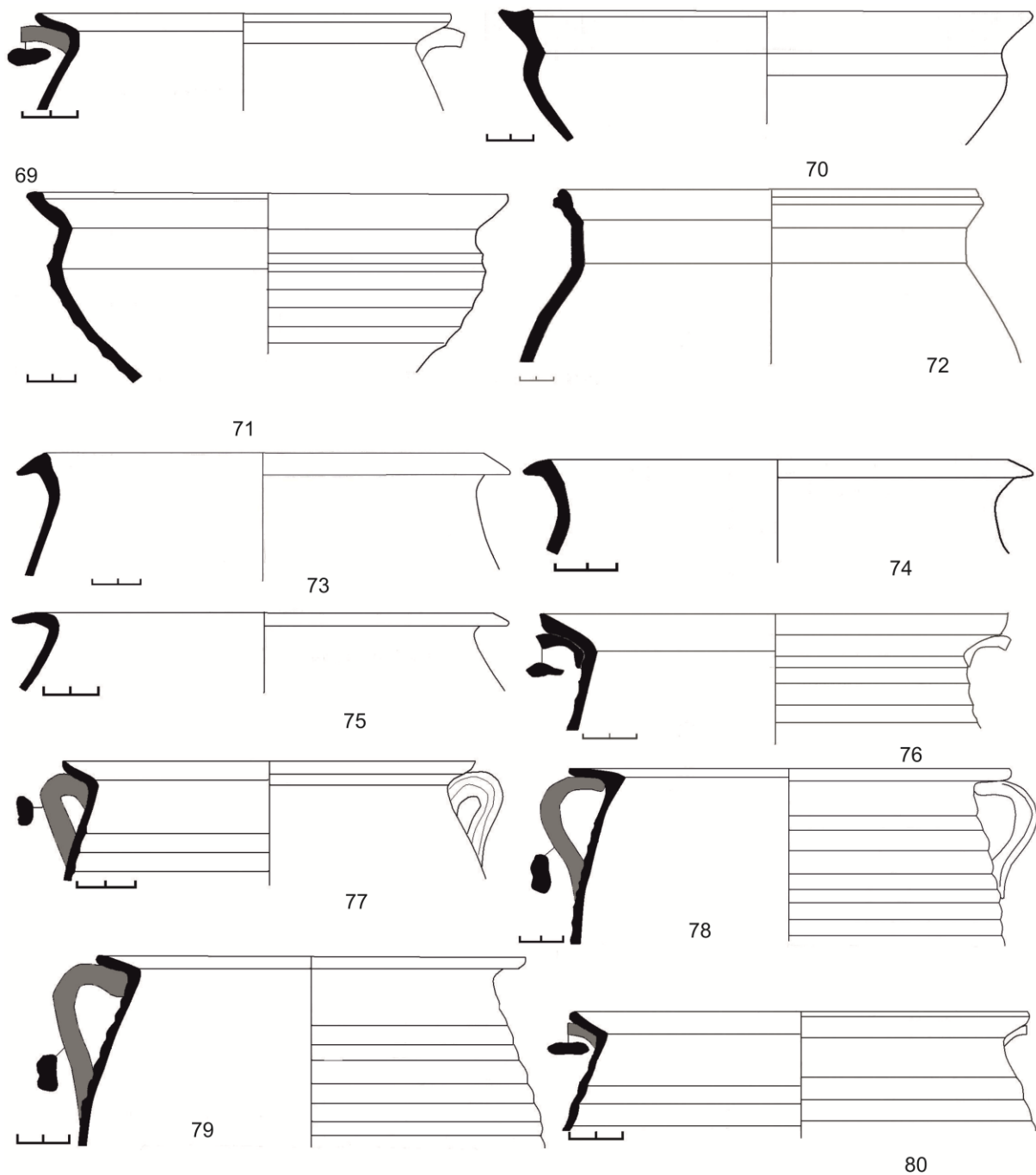

82. T6, C3, pot, a fragment of the upper part, r.d.–24 cm, p.h.–5.5 cm, pink semi-fine fabric with rare particles of limestone, self-slip, secondarily fired at the outside, Munsell 2.5YR 5/8 red. Wide flaring rim grooves on the median part;
83. T6, C3, pot or casserole, fragment of upper part, r.d. 26 cm, p.h. 4,5 cm, semi fine reddish fabric with rare red particles in composition, self-slip, traces of brownish-gray paint at the outside, Munsell 5YR 7/6 reddish yellow. Wide flaring rim.

**Honcu 2017 storing pots/*dolia* type I, 79-80, pl. XIII/124-125 (2<sup>nd</sup>-3<sup>rd</sup> c. AD); Suceveanu 2000, pl. 51/1-5, type XXXVI / A (2<sup>nd</sup>-3<sup>rd</sup> c. AD)**

The rim is triangle in section, thickened and vertical, globular body decorated with grooves, the single example is presenting handles.

84. T1, C1, pot, a fragment of the rim, r.d.–18 cm, p.h.–4 cm, coarse reddish-grey fabric with sand in composition, secondarily fired at the inside and outside, the handle is oval in section, the body is decorated with grooves on the median part, triangular rim, Munsell 2.5Y7/3 pale yellow;

**Honcu 2017 pots type IV, 53, pl. IV/35-40, pl. V/41-50 (2<sup>nd</sup>-3<sup>rd</sup> c. AD); Suceveanu 2000, pots type XL, pl. 60-62**

This type presenting an almost vertical rim, thickened and flat at the top, a globular body decorated with grooves and oval handle in section.

85. T1, C1, pot, fragment of rim, p.h.–3.5 cm, r.d.–12 cm, semi fine reddish fabric with limestone and silver mica in composition, brown slip, the vessel is decorated with grooves in the median part, Munsell 7.5YR 8/6 reddish yellow
86. T6, C3, pot, a fragment of the rim, r.d.–20 cm, p.h.–4 cm, beige coarse fabric, rough, with limestone particles in composition, slip at the same colour, grey core, secondarily fired at the outside, Munsell 10YR 6/8 brownish-yellow. The rim is flattened, reversed to the outside, flattened handles.

**Honcu 2017 pots type III, 51-52, pl. IV/31, (3<sup>rd</sup>-4<sup>th</sup> c AD); Suceveanu 2000, type XL, pl. 60/3**

The rim is thickened at the outside, flat on the top, globular body. No handles identified.

87. T3-T4, C3, pot, a fragment of rim and body, r.d.–14.5 cm, p.h.–12 cm, oxidative firing, coarse orange fabric with sand in composition, Munsell 6,5YR 8/6 reddish-yellow. The rim is flat, globular body, no handles preserved;
88. T3, C3 pot, a fragment of the rim, r.d.–15 cm, p.h.–4.5 cm, coarse, rough orange fabric with sand, slip at the same colour, Munsell 7.5ZR 8/6 reddish yellow;
89. T3, C3, pot, a fragment of rim and median part, r.d.–14 cm, p.h.–14 cm, coarse reddish fabric with sand, secondarily fired at the outside and inside, reddish coating, Munsell 2.5Y 7/4 pale yellow. The rim is flat, thickened to the outside, the body is globular, no handles identified.

**Honcu 2017 pots type I, p. 43, pl. I/6, pl. II/11-20, pl. III/21-22, 25 (1<sup>st</sup>-3<sup>rd</sup> c. AD);**

The rim is funnel-shaped, sometimes thickened, bent to the inside, a globular body, oval handles decorated with grooves. From 11 fragments discovered, belonging to different examples, 7 potsherds don't have handles preserved. From the 4 potsherds with handles, a single example preserving the entire rim is having certainly a single handle. For the rest of

the 3 examples, the fragments preserved are too small and both handles represent a graphic restitution, even the fragments preserve a single handle.

90. T1, C1, pot, a fragment of the rim, r.d.–22 cm, p.h.–7 cm, coarse pale yellow fabric with sand in composition, insufficient fired reddish core, secondarily fired at the outside, oval handles decorated with grooves, Munsell 2.5Y 8/2 pale yellow;

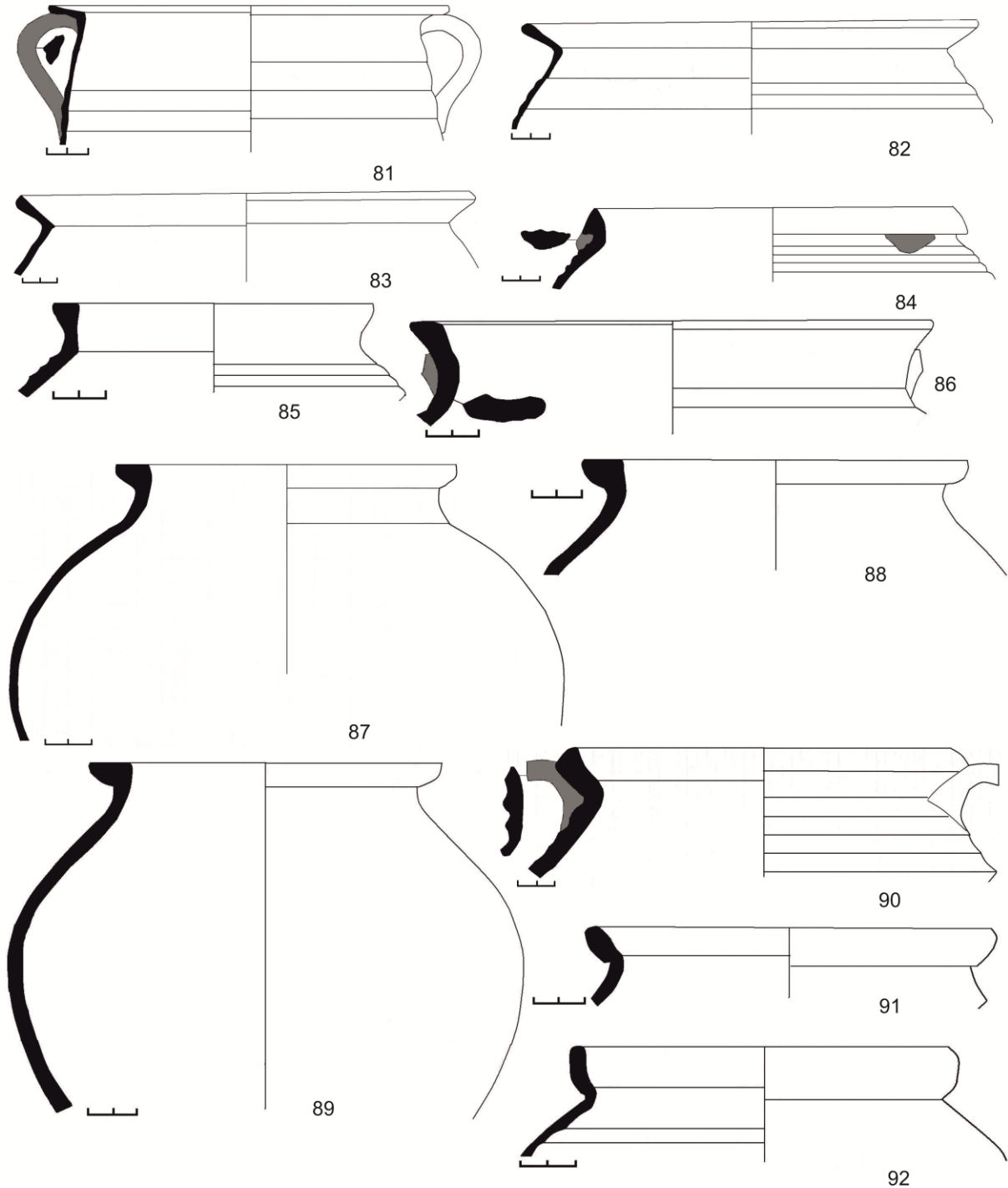



91. T1, C1, pot, fragment of rim, r.d.–16 cm, p.h.–3 cm, coarse pale yellow fabric with sand in composition, secondarily fired at the outside, Munsell 10 YR 8/3 very pale brown;
92. T1, C1, pot, a fragment of the rim, p.h.–4 cm, r.d.–14 cm, pale yellowish coarse fabric with fine sand in composition, yellow slip at the outside, Munsell 5Y8/4 pale yellow;
93. T6, C3, pot, a fragment of the upper part, r.d.–13 cm, p.h.–5.5 cm, semi coarse whitish fabric with fine sand in composition, whitish slip, secondarily fired at the outside, Munsell 10YR 8/4 pale brown. The rim is slightly funnel-shaped;
94. T6, C3, pot, a fragment of the upper part, r.d.–13 cm, p.h.–5 cm, whitish fabric with fine sand, secondarily fired at the outside, Munsell 10 YR 8/4 pale brown. The rim is slightly funnel-shaped;
95. T6, C3, pot, a fragment of the upper part, r.d.–11.3 cm, p.h.–4 cm, whitish fabric with fine sand, small stones and red particles in composition, secondarily fired at the outside Munsell 10 YR 8/4 pale brown. The rim is slightly funnel-shaped;
96. T1, C1, single handle pot or cup, a fragment of the upper part, r.d.–11.5 cm, p.h.–7 cm, oxidative firing, semi-fine reddish fabric with rare limestone particles in composition, pale yellow slip at the inside and outside, secondarily fired at the outside, Munsell 10YR 8/8 yellow. The rim is rounded, presenting a lid-seating on the inside, oval handle in section;
97. T1, C1, pot, a fragment of the rim, r.d.–22.5 cm, p.h. 3,5 cm, oxidative firing, coarse pink fabric with iron oxide, red and white particles in composition, secondarily fired at the outside, Munsell 10YR 8/3 very pale brown. The rim is faceted, slightly reverted to the outside with a small concavity for accepting a lid;
98. T6, C5, pot, a fragment of the upper part, r.d.–13 cm, p.h.–4.5 cm, pale yellow, rough fabric with fine sand and limestone particles, secondarily fired at the exterior, flat handle in section, Munsell 2.5Y 8/3 pale yellow. Wide flaring rim presenting a lid-seating;
99. T1, C1, pot, a fragment of the rim, r.d.–16 cm, p.h.–4.5 cm, whitish coarse fabric with sand in composition, secondarily fired at the exterior, Munsell 2.5Y 8/2 pale yellow. The flaring rim is reverted at the top to the inside, globular body;
100. T1, C1, pot, a fragment of the upper part, r.d.–20 cm, p.h.–7 cm, whitish coarse fabric with sand in composition, secondarily fired at the outside, Munsell 2.5 Y 8/3 pale yellow. Funnel-shaped rim slightly reverted to the inside, globular body; flat handles in section, decorated with grooves;

**Suceveanu 2000, pot type XXXVII, pl. 52 /3, 8, 2<sup>nd</sup>-3<sup>rd</sup> c. AD**

The rim is vertical, flat on the top, the neck is short, the body of the vessel is bag-shape, decorated with grooves. This type of pot may be earlier than the rest of the assembly.

101. T6, C3, pot, fragment of the upper part, r.d.–16 cm, p.h.–8.5 cm semi coarse brick colour fabric with fine sand and limestone particles in composition, secondarily fired at the outside, self-slip at the inside and outside, Munsell 10R 3/4 dark red. The vessel is presenting grooves at the medium part of the wall. The rim is vertical; the lip is flat on the top;

**Opaiț 2004, pots type II, 45 (4<sup>th</sup>-5<sup>th</sup> c. AD); Suceveanu 2000, pots type XXXVI, 119, pl. 51/12 (second half of the 3<sup>rd</sup> c. AD); Honcu 2017, pots type IX, 63, pl. VIII/74 (2<sup>nd</sup> c. AD)**

The rim of the pot is concave, the body is globular.

**102.** T6, C3, pot, a fragment of the rim, p.h.–4 cm, r.d.–18 cm, oxidative firing, reddish semi-fine fabric with silver mica sparkles and limestone particles, porous, granulated, reddish slip, Munsell 2.5YR 7/8 light red. Lid-seating on the sloping rim;

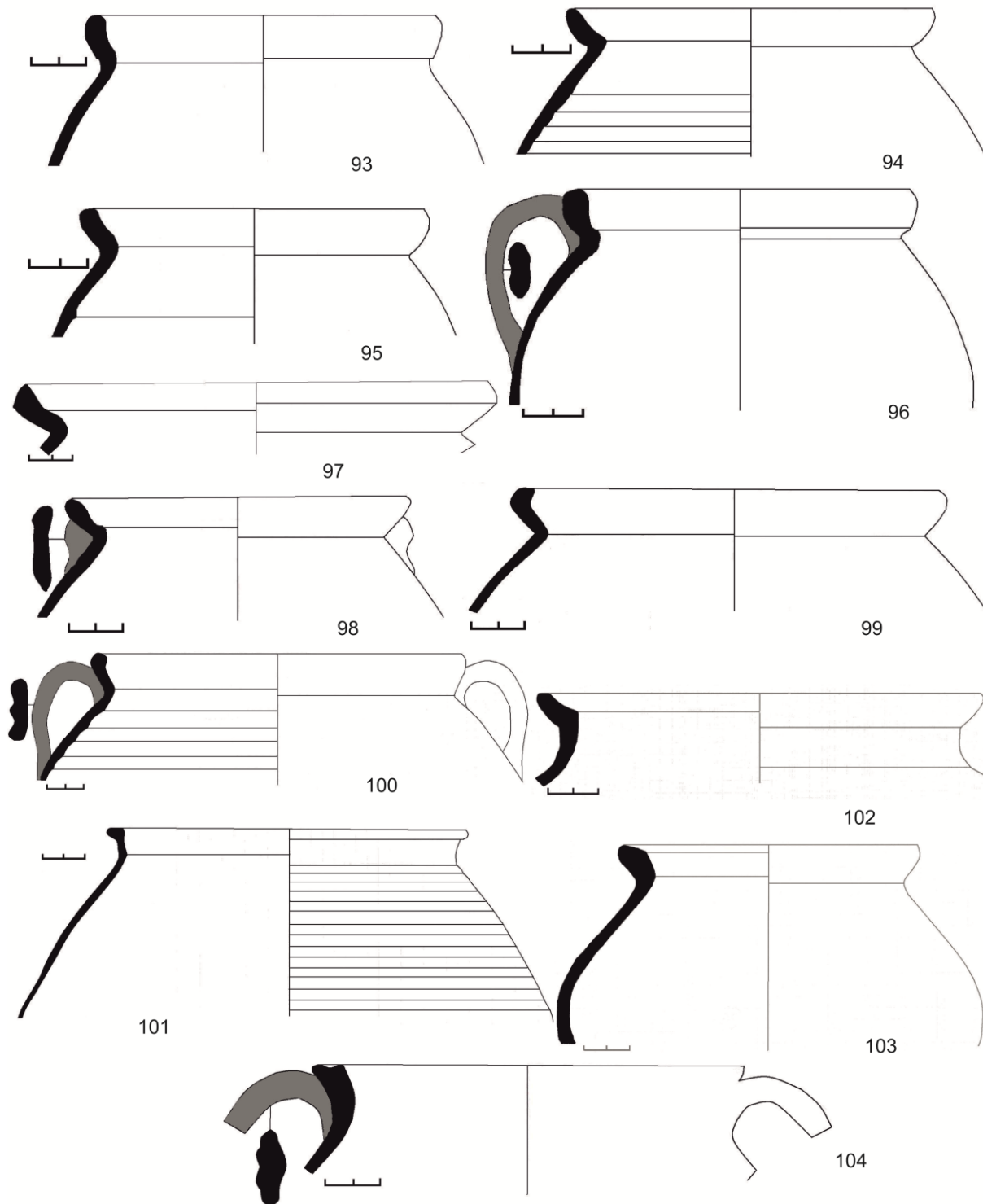

**Honcu 2017, storing pots/*dolia* type III, 81, pl. XII/127 (1<sup>st</sup>-3<sup>rd</sup> c. AD); Suceveanu 2000, pots type XL, pl. 62/30**

The rim is thickened on the top, beveled; the body is globular in shape.

**103.** T6, C3, pot, a fragment of the upper part, r.d.–13 cm, p.h.–8.5 cm, oxidative firing, reddish coarse fabric with limestone and sand particles, Munsell 7.5YR 7/6 reddish yellow thickened rim, slightly reverted and flatted on the top;

**Opaiț 2004, pots type III, 45-46 (4<sup>th</sup>-5<sup>th</sup> c. AD);**

The rim is thickened, presenting a groove for the lid-seating on the top, the body is globular, decorated with grooves, oval-shaped handles in section.

**104.** T3-T4, C3, pot, a fragment of rim and handle, r.d.–16 cm, p.h.–4 cm, oxidative firing, coarse yellowish fabric with sand in composition, secondarily fired at the outside, Munsell 2.5Y 8/3 pale yellow. Lid-seating on the top of the reverted rim, oval handles in section, decorated with grooves. Additional analogies: Suceveanu 2000, type XL, pl. 61/15 (2<sup>nd</sup>-3<sup>rd</sup> c. AD);

**105.** T3, C3, pot, a fragment of the rim and upper part, r.d.–15 cm, p.h.–9 cm, coarse reddish-brown fabric with small stones and limestone particles in composition, the handle is oval in section, decorated with grooves, the body of vessel presents grooves in the median part, Munsell 2.5Y 7/8 yellow. Lid-seating on the rim;

**106.** T3, C3, pot, a fragment of the rim, r.d.–14 cm, p.h.–5.5 cm, semi coarse yellowish fabric with sand in composition, slip at the same colour, the handle is oval in section, decorated with grooves, secondarily fired at the outside and inside, Munsell 2.5Y 8/2 pale yellow. Lid-seating on the rim; grooves at the medium part of the body;

**Varia**

**107.** T6, C3, pot, a fragment of the base, flat, base d. 14 cm, p.h.–4 cm, oxidative firing, coarse fabric with sand, secondarily burned at the outside and inside, Munsell 2.5 YR 6/8 light red;

**LIDS**

**Honcu 2017, lids type 1, pl. XXIX/264, 267-268, p. 127, 2<sup>nd</sup>-3<sup>rd</sup> c. AD**

**108.** T6, C3, lid, a fragment of the rim, p.h.–6.5 cm, r.d.–24 cm, oxidative firing, coarse reddish fabric with limestone particles, Munsell 5YR 7/8 reddish yellow, the rim is flattening on the outside and oblique on the inside;

**109.** T1, C1, lid, a fragment of the base, p.h.–4 cm, base d.–24 cm, oxidative firing, reddish coarse fabric with sand in composition, yellow slip at the inside and outside, Munsell 7.5YR 8/4 pink. The base is curved to the inside;

**Honcu 2017, lids type 2, 2<sup>nd</sup>-3<sup>rd</sup> c. AD, 129, pl. XXX/277-282**

**110.** T6, C3, lid, fragment, p.h.–10 cm, base d.–22 cm, oxidative firing, beige fabric with limestone particles and silver mica, the core is grey, secondarily burned at the inside and outside, Munsell 10 YR 7/8 yellow. Circular 6 cm diameter wheel – pinched knob;

**111.** T1, C1, lid, a fragment of the lower part, p.h.–5 cm, r.d.–22 cm, light brick colour, coarse fabric with sand in composition, light yellow slip, secondarily fired on the inside and outside, Munsell 2.5Y 8/3 pale yellow;

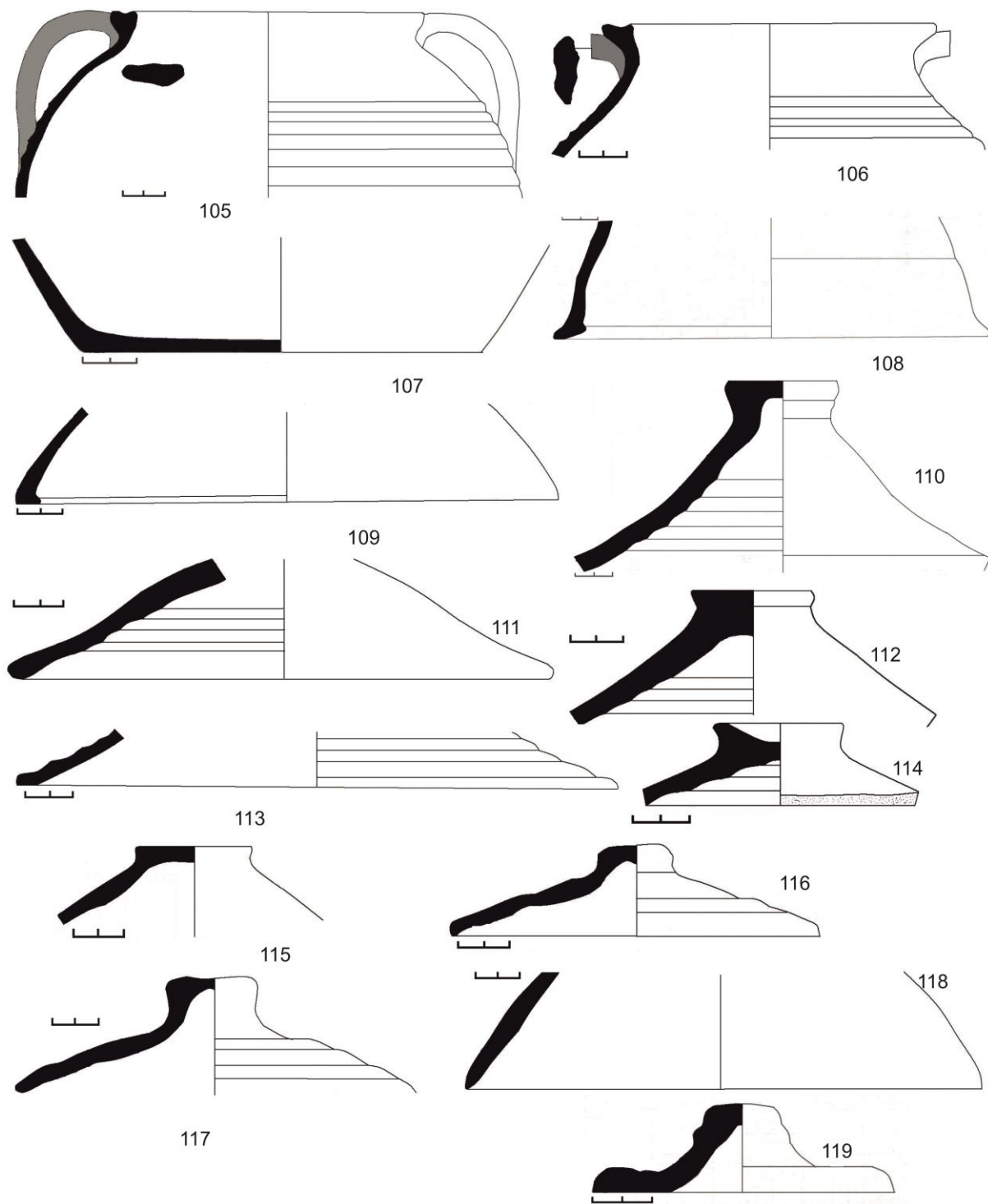

**112.** T1, C1, lid, a fragment of the upper part, p.h.–5 cm, knob d.–4.5 cm, coarse, brick colour fabric with sand, red and black particles in composition, porous, secondarily fired on the inside and outside, Munsell 10R 6/6 light red;

**113.** T1, C1, lid, a fragment of the lower part, base d.–26 cm, p.h.–2.5 cm, coarse brick colour fabric with sand and small stones in composition, secondarily fired at the inside and outside, Munsell 10YR 7/6 yellow;

**114.** T6, C3, lid, a fragment of the upper part, p.h.–3 cm, knob d.–4.5 cm, semi coarse reddish colour fabric with fine sand in composition, Munsell 10R 4/4 weak red;

115. T6, C3, lid, fragment, p.h.–3 cm, oxidative firing, semi-fine reddish fabric with limestone particles in composition, red slip at the inside and outside, Munsell 7.5 YR 8/6 reddish yellow;
116. T6, C3, lid, fragment, knob d.–3 cm, p.h.–3.5 cm, coarse brick colour fabric with limestone particles, secondarily fired at the inside and outside, Munsell 5YR 6/8 reddish yellow;
117. T6, C3, lid, fragmentary, p.h.–5 cm, maximum d.–17.5 cm, knob d.–4 cm, reduced firing, coarse greyish fabric with sand in composition, secondarily fired, Munsell 1 for Gley 4/ dark grey;

**Honcu 2017, lids type 2, 2<sup>nd</sup>-3<sup>rd</sup> c. AD, 129, pl. XXIX/273**

118. T3, C3, lid, a fragment of the rim, p.h.–5 cm r.d.–22 cm, semi coarse reddish fabric with silver mica and limestone particles, red paint at the inside and outside, Munsell 7.5YR 8/6 reddish yellow;

**Böttger 1982, Tafel 25/558 (Iatrus)**

119. T6, C3, lid, fragment, p.h.–3 cm, base d.–10 cm, reduced firing, coarse greyish fabric with sand, limestone and small stones, Munsell 2 for Gley 6/1 bluish grey;

**Melting pots**

**Chiriac, Boțan 2013; Boțan, Paraschiv, Nuțu, 2010**

120. T6, C3, a fragment of a melting pot base, p.h.–3.5 cm, base d.–10 cm, oxidative firing, porous, reddish coarse fabric containing sand and limestone particles, whitish slip on the outside, flat base, negligent execution, traces of vitrification on the inside, exfoliated inside;
121. T5-T6, C1, melting pot, a fragment of the base, base d.–8.5 cm, p.h.–7 cm, coarse grey fabric with limestone particles, the inside of the vessel is vitrified, the base is perforated Munsell 1 for Gley 6/1 greenish grey.

**AMPHORAE & TABLE AMPHORAE**

**Pontic amphorae**

**Heraclea.**

**Зеецт 1960 types 64, 91-94, 104-105; Paraschiv 2006, Pontic amphorae, type 3, 19-24, pl. 1-3; Paraschiv 2013, fig 1-2**

122. T6, C3, amphora fragment, p.h.–5 cm, base d.–3 cm, oxidative firing, reddish fabric with small particles of limestone, Munsell 7.5YR 8/6 reddish yellow, conical base;
123. T6, C3, amphora fragment, p.h.–5 cm, base d.–2.5 cm, oxidative firing, light reddish fabric with white particles in composition, reddish-yellow coating on the outside, Munsell 7.5YR 8/6 reddish yellow, the base is conical shaped;
124. T6, C8, amphora, a fragment of rim and neck, p.h.–10 cm, r.d.–7 cm, oxidative firing, yellowish fabric with iron oxide and black particles in composition, yellowish coating, traces of red dipinti on the neck, rounded handles in section, Munsell 10 YR 8/8 yellow;
125. T6, C 3, amphora, a fragment of rim and neck, p.h.–8 cm, r.d.–6.4 cm, oxidative firing, reddish fabric with silver mica sparkles and black particles, the handle has more ridges running down it, Munsell 10 YR 8/8 yellow;

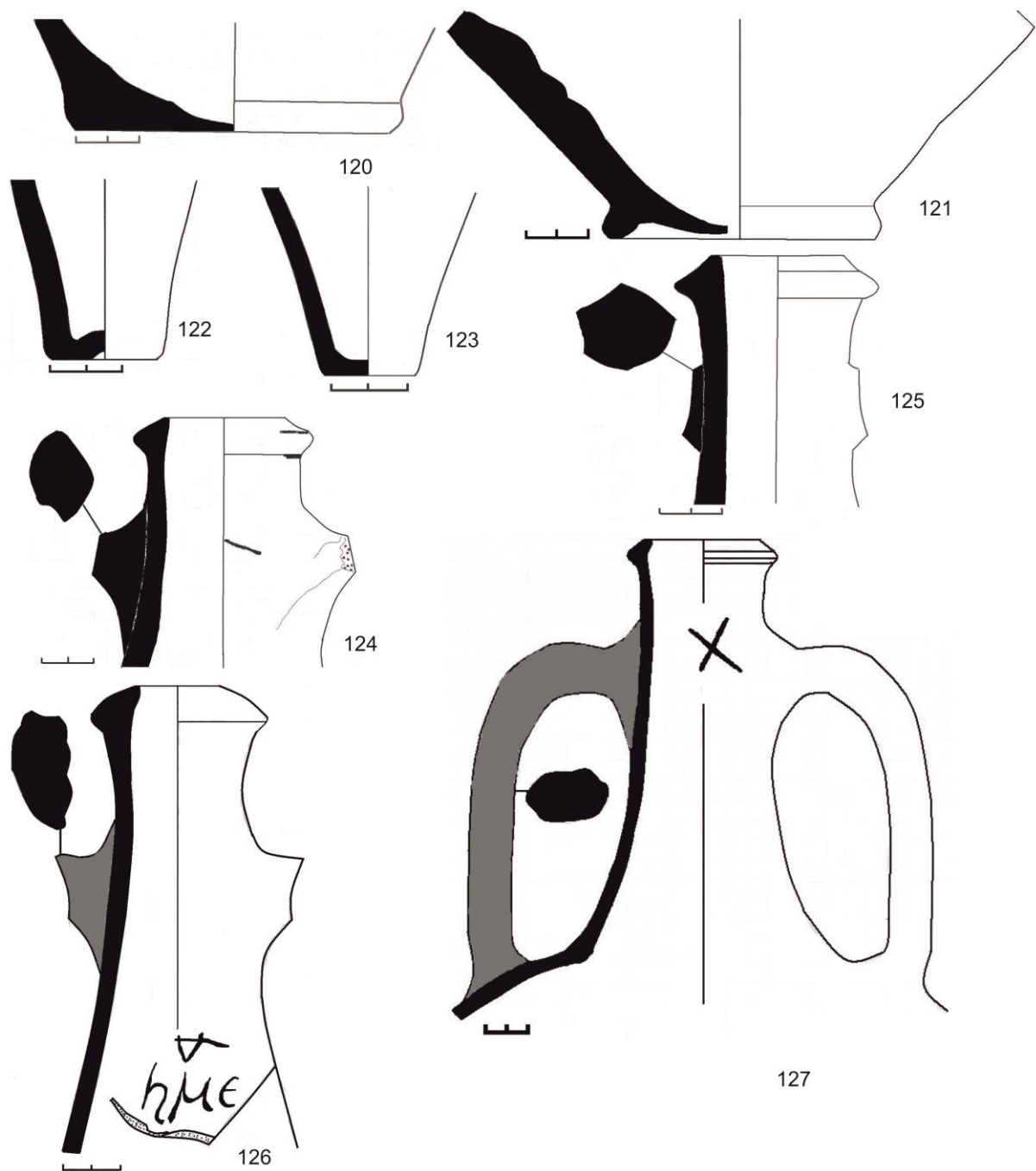

- 126.** T6, C2, amphora, a fragment of the upper part, r.d.–6 cm, p.h.–16 cm, oxidative firing, brick colour fabric with limestone and iron oxide particles, Munsell 7.5 YR 8/6 reddish-yellow. Red *dipinti* on the neck;
- 127.** T9, C15, amphora, a fragment of rim and neck, r.d.–7.5 cm, p.h.–24 cm, oxidative firing, brick colour fabric with limestone and black microparticles in composition, Munsell 7.5YR 8/6 reddish-yellow. X shape *grafitti* on the neck;
- 128.** T1-T2, amphora, a fragment of neck and rim, r.d.–5 cm, p.h.–10.5 cm, reddish fabric, oval handle in section, Munsell 10YR 7/6 yellow;

- 129.** T3, C3, amphora, fragment of rim, r.d.–6.5 cm, p.h.–4.5 cm, yellowish, porous fabric with silver mica, yellowish coating, Munsell 2.5Y 8/2 pale yellow;
- 130.** T17, amphora, a fragment of the upper part, r.d.–5.5 cm, p.h.–26.5 cm, oxidative firing, light beige fabric with black and mica particles in composition, secondarily fired at the inside and rim, red *dipinti*, oval handle in section, Munsell 2.5Y 8/6 yellow. ηH = 8 ήμκοτύλη (8 x 136.4 ml = 1.056 liter).<sup>18</sup> ψιχ = alternative translations: ψύχω – ψύχτήριος = cooling, refrigerants; ψύχη = spirit; ψίθιος = a rough, harsh red wine;
- 131.** T8, C3, amphora, a fragment of rim and neck, r.d.–4 cm, p.h.–5.5 cm, semi-fine reddish fabric with limestone particles, Munsell 10R 6/8 light red;
- 132.** T1, C15, fragment from an amphora neck, yellowish fabric with iron oxide and sand in composition, Munsell 2.5Y 8/3 pale yellow, red *dipinti* τρυ = τρυ(γία). One Selov F amphora from Heraklea Pontica (second half of the 4<sup>th</sup> c. AD), discovered in Athenian Agora was bearing the same *dipinti* representing τρυ(γία) with a capacity of cca. 10 *litrai* (1 χοῦς). Lang 1976, 80, He 32, pl. 46; Opaït 2010, 111; Okan, Bilir 2020, 341.

**Dyczek 2001, type 29; Zeest 1960, type 91, 92, 93**

- 133.** T6, C3, amphora, almost complete, r.d.–6 cm, p.h.–31 cm, oxidative firing, brick colour fabric with limestone and silver mica sparkles, no coating, Munsell 10 YR 7/8 yellow. The body of the amphora is piriform, oval handles in section, conical neck and triangular rim. Mathematical measurement of volume: ± 1 liter. 2<sup>nd</sup>-3<sup>rd</sup> c. AD;

**Zeest 1960, type 75; Paraschiv 2006, type 6, p. 27, pl. 5/33-35, 2<sup>nd</sup>-3<sup>rd</sup> c. AD**

- 134.** T1, C1, a fragment of the rim, p.h.–4.5 cm, r.d.–26 cm, dark brick colour fabric with limestone particles, porous, rough, dark brick colour coating Munsell 5 YR 6/8 reddish yellow;
- 135.** Roman Crypt, amphora, fragment of base, p.h.–20 cm, reddish rough, coarse fabric with small stones and limestone in composition, reddish colour coating, traces of mortar of chalk at the exterior, Munsell 2.5YR 7/8 light red. Knobbed base, grooves at the median part;
- 136.** T1, C1, amphora, 2 fragments of rim, r.d.–24 cm, p.h.–5.7 cm, red fabric with iron oxide, limestone, red colour surface treatment, Munsell 2.5YR 6/8 light red.

**Pontic amphora 3εεστ 1960, type 84-85, pl. 35; Paraschiv 2006, Pontic amphora type 4, pl. 3-5/22-30, 2<sup>nd</sup>-3<sup>rd</sup> c. AD**

- 137.** T1, C1, amphora, fragment of rim, p.h.–2.5 cm, r.d.–11 cm, oxidative firing, reddish fabric with black particles in composition, reddish coating, Munsell 7.5YR 7/6 reddish-yellow. Băjenaru 2014, p. 116, fig. 9/138, 139 (Histria). Uncertain origin, context of 2<sup>nd</sup> c. AD;
- 138.** T6, C3, amphora, a fragment of the rim, r.d.–11 cm, p.h.–4 cm, oxidative firing, red, homogenous fabric with limestone particles in composition, red coating, Munsell 2.5YR 5/8 red. Băjenaru 2014, p. 116, fig. 9/134 (Histria), possibly Pontic, context of 2<sup>nd</sup> c. AD;
- 139.** T6, C5, amphora, fragment of rim, r.d.–13 cm, p.h.–4.5 cm, oxidative firing, reddish fabric with limestone and iron oxide particles, Munsell 10R 4/8 red. The rim is thickened, slightly reverted to the exterior. Băjenaru 2014, p. 116, fig. 9/134 (Histria), possibly Pontic, context of 2<sup>nd</sup> c. AD.

<sup>18</sup> Mathematical measurement of volume: ± 1 liter.

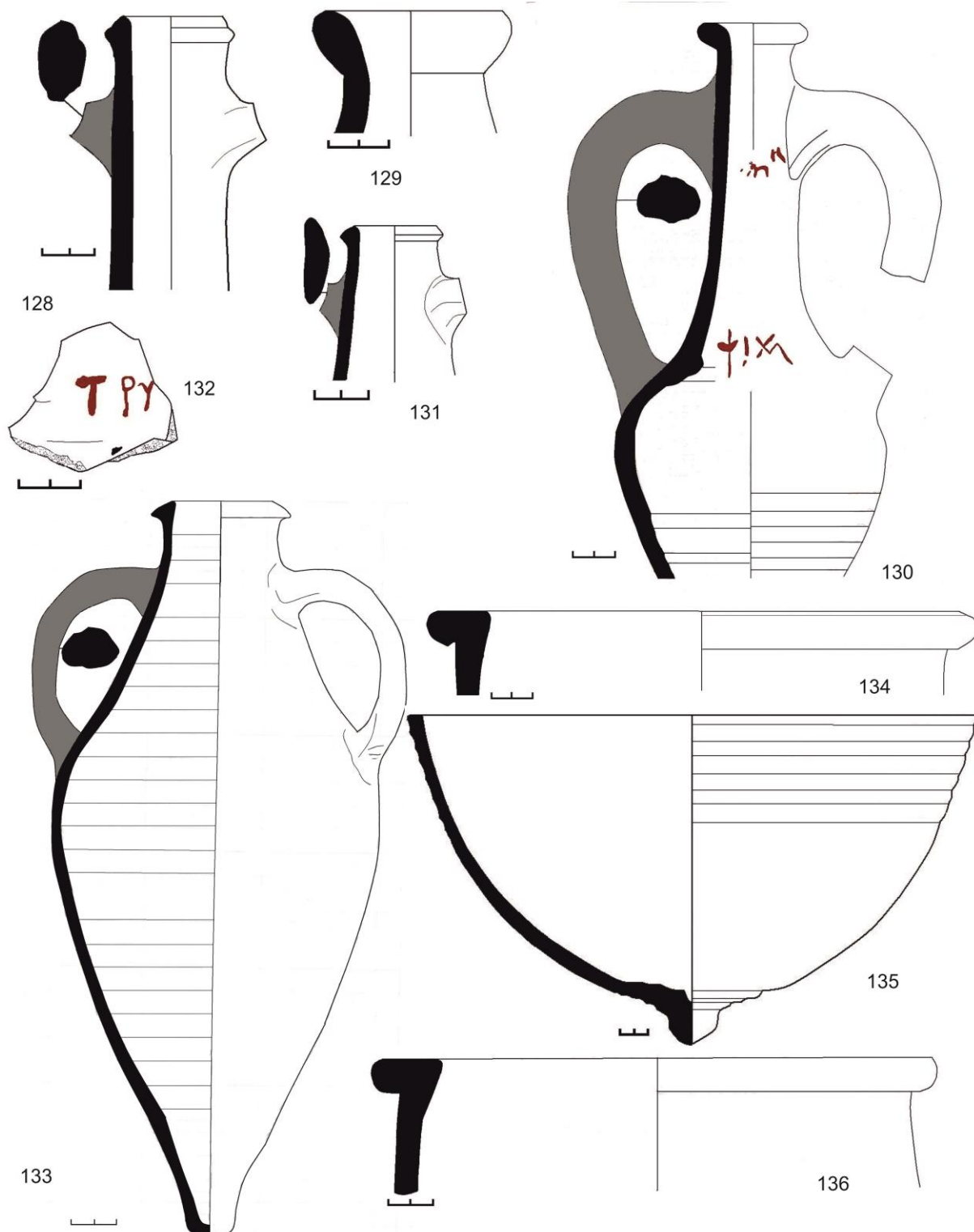

### Table amphora

#### Opaiț 2003, 216, types 2 and 3, fig. 5-6

**140.** T6, C3, amphora fragment, oxidative firing, p.h.–14 cm, r.d.–11 cm, light reddish homogenous fabric containing iron oxide and other black particles, yellow coating on the outside, Munsell 5Y yellow, the rim is thickened outwards, the neck is cylindrical, the handles are oval, decorated with grooves;



- 141.** T6, C3, base fragment of a table amphora, p.h.–15 cm, base d.–11.5 cm, both reducing and oxidative firing, grey fabric, porous, containing limestone particles, red color on the exterior, traces of red coating at the outside and brown at the inside of the body, Munsell 7.5 YR 8/6 reddish yellow, ring-shaped base;
- 142.** T6, C3, a fragment of the rim, p. h. 4 cm, r. d. 12 cm, oxidative firing, reddish fabric containing particles of limestone and silver mica, reddish coating, Munsell 10R 7/8 light red. The rim is thickened outwards, flat handle in section. Opaïț 2003, p. 217, table amphora subtype 5A, pl. 8 (2<sup>nd</sup> c. AD - Troesmis);
- 143.** T6, C3, amphora, a fragment of the upper part, p.h.–18 cm, r.d.–11 cm, oxidative firing, reddish fabric with small particles of limestone, red coating on the outside, Munsell 2.5YR 7/6 light red. The rim is slightly thickened, the neck is cylindrical and the handles are oval in section, decorated with grooves;
- 144.** Roman crypt, amphora, fragmentary, r.d.–12 cm, p.h.–18 cm, reddish fabric with small particles of limestone in composition, surface treatment at the same colour, traces of red paint at the exterior careless and irregular applied, traces of mortar at the inside and outside, Munsell 2.5YR 6/8 light red. Possibly 4<sup>th</sup> c. AD table amphora.

#### **Table pitcher or table amphora**

##### **Simion 2007, fig. 7 (Noviodunum)**

- 145.** T6, C3, rim fragment and handle, p.h.–16 cm, r.d.–11 cm, oxidative firing, grey colour fabric with limestone particles, beige – reddish colour at the outside, Munsell 10YR 7/8 yellow, slightly thickened rim, the handles are oval-shaped in section, decorated with grooves. The second handle was drawn by graphic restitution, being preserved a single handle;
- 146.** T1, C1, a fragment of the rim and handle, r.d.–10 cm, p.h.–5 cm, dark brick colour fabric with limestone and black particles in composition, surface treatment on the same colour, oval handle in section, Munsell 5 YR 6/8 reddish-yellow. The second handle was drawn by graphic restitution, being preserved a single handle;
- 147.** T6, C3, a fragment of the handle, p. length–17 cm, oxidative firing, light brick color fabric with iron oxide and limestone particles, light brick colour coating, Munsell 7.5 YR 8/4 pink The handle is oval in section, decorated with grooves.

#### **Oriental amphorae**

##### **Kapitän 2/Berenice MRA 7.**

##### **Paraschiv 2006, type 41, 87-89, pl. 20/31-32; Opaïț 2004, 13, pl. 8/6 Tomis (Robinson M237); Opaïț, Ionescu 2016, pl. IV/20-30**

- 148.** T6, C3, amphora fragment of the base, p.h.–8 cm, base d.–6 cm, oxidative firing, reddish fabric containing iron oxide particles, Munsell 7.5 YR reddish yellow;
- 149.** T6, C3, amphora fragment of handle and neck, p.h.–10 cm, oxidative firing, reddish fabric containing limestone particles, red coating, Munsell 2.5 YR 6/8 light red;
- 150.** T6, C3, amphora, fragment, neck and handles, p.h.–12.5 cm, oxidative firing, reddish fabric with limestone particles, whitish coated, red *dipinti* on the neck, Munsell 10YR 8/8 yellow. The handle is oval in section, decorated with groove;
- 151.** T6, C3, amphora, a fragment of the upper and median part, p.h.–27 cm, r.d.–6.5 cm, oxidative firing, reddish fabric with limestone and rare iron oxide particles, reddish coating, Munsell 5YR 7/8 reddish-yellow. Oval handles in section, grooves inside the long neck;

- 152.** T 3-4, C3, Roman crypt, a fragment of rim and neck, r.d.–6 cm, p.h.–22.5m, reddish fabric with limestone and black particles, reddish coating, Munsell 5YR 6/8 reddish yellow;
- 153.** T1, C1, a fragment of the base, p.h.–5.5 cm, base d.–10 cm, red fabric with limestone and iron oxide in composition, Munsell 2.5YR 5/8 red;
- 154.** T6, *passim*, a fragment of the upper part, r.d.–5 cm, p.h.–7 cm, reddish brick colour fabric with limestone particles in composition, Munsell 2.5YR 6/8 light red;



137

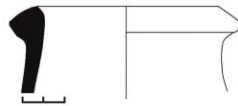

138

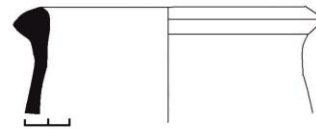

139

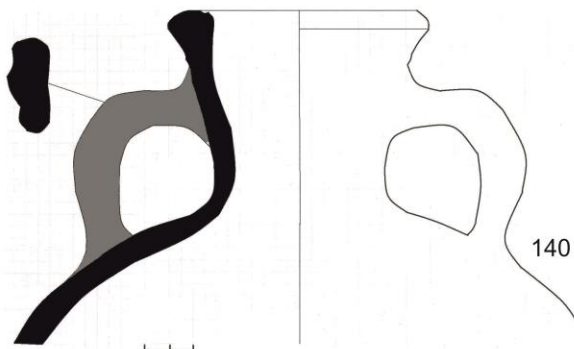

140

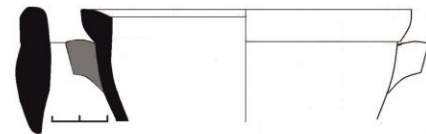

142

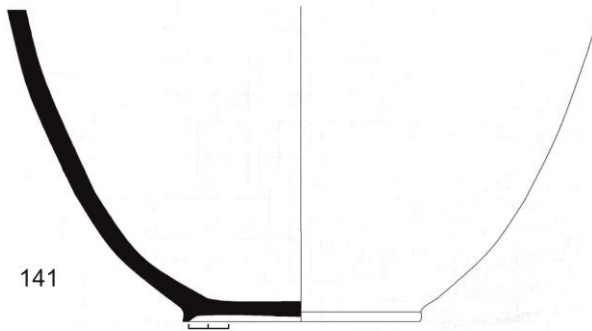

141

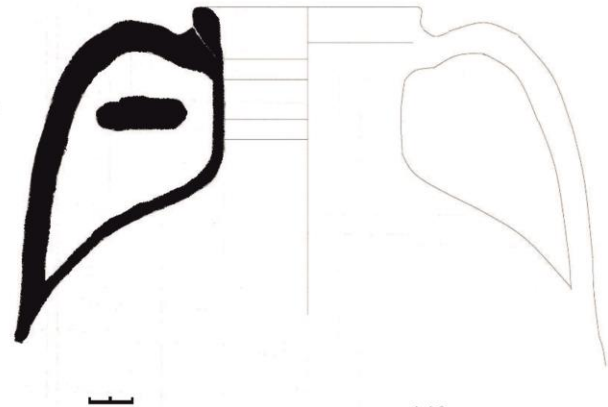

143

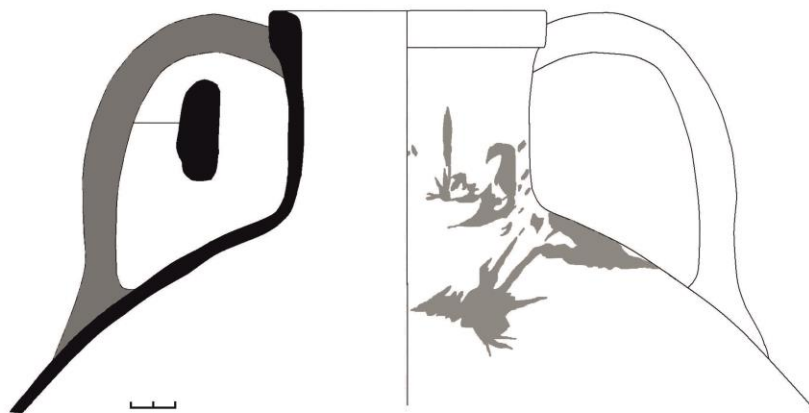

144

**Berenice MRA3**

These amphorae are also attested in the Noviodunum necropolis (Simion 2007, fig. 7-example with two handles). Paraschiv 2006 type 38, 1<sup>st</sup>-4<sup>th</sup> c AD, 83, pl. 18/19-21; Robinson pl. 23/M125-126; Opař 2004, 13-14

155. Roman crypt, complete, r.d.–4.5 cm, h.–40 cm, oxidative firing, reddish fabric with limestone particles in composition, red painting at the upper and median part, Munsell 10 YR 8/8 yellow. The amphora is complete, presenting a single handle, oval in section, decorated with grooves; the body is presenting grooves;

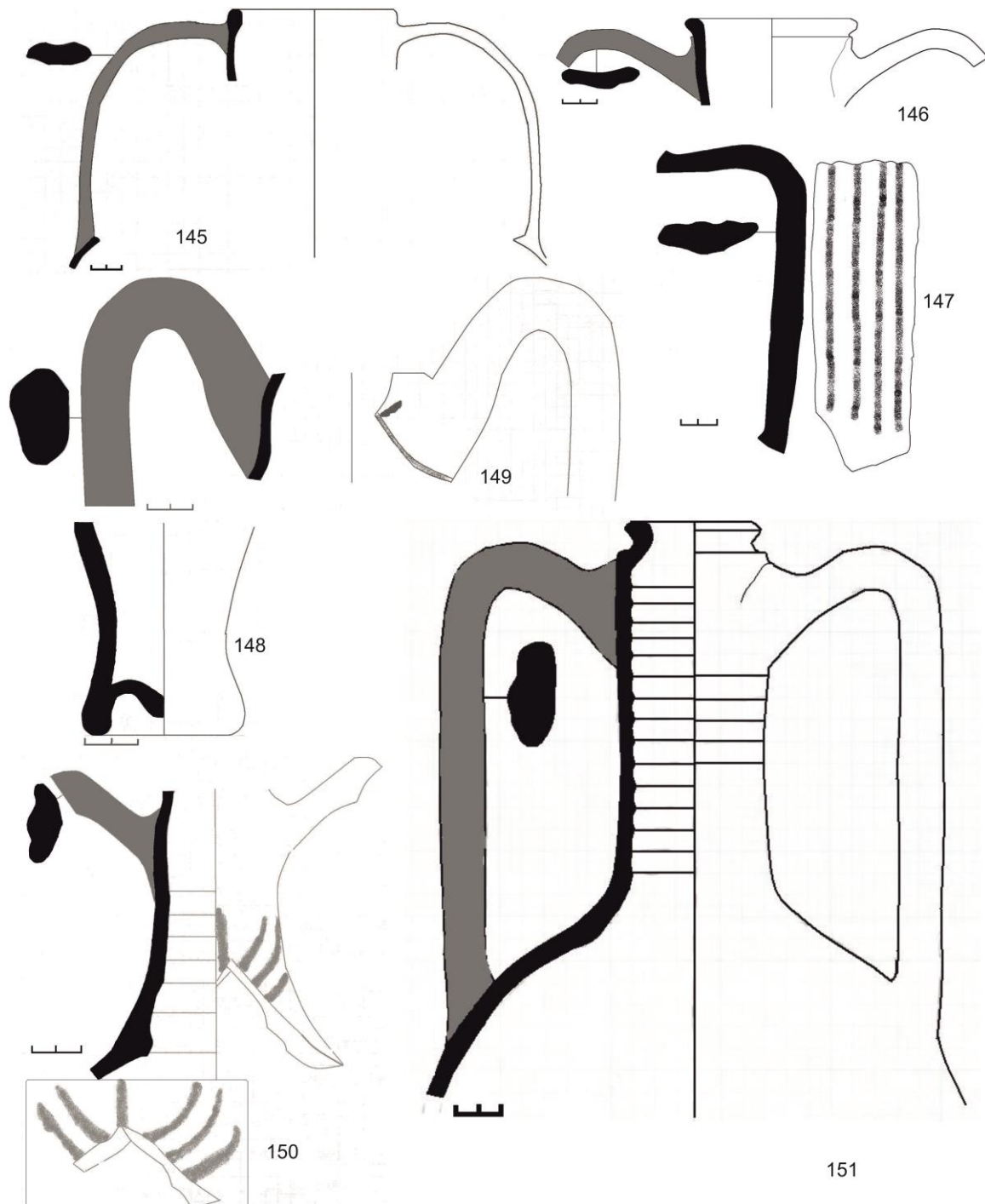

**Berenice MRA 10/Carthage LRA 3.****Paraschiv 2006 type 39, 84-86, pl. 19/23-27; Opaț 2004, pl. 7/5 (LRA3)**

**156.** T6, C3, fragment of amphora base, p.h.–3.5 cm, base d.–3.8 cm, oxidative firing, semi-fine reddish fabric with black particles in composition, reddish coating, secondarily fired, Munsell 7.5YR 7/8 reddish yellow;

**157.** T6, C3, fragment of amphora base, p.h.–3 cm, base d.–3.5 cm, oxidative firing, semi-fine brown-reddish fabric, reddish coating, Munsell 2.5YR 6/8 light red;

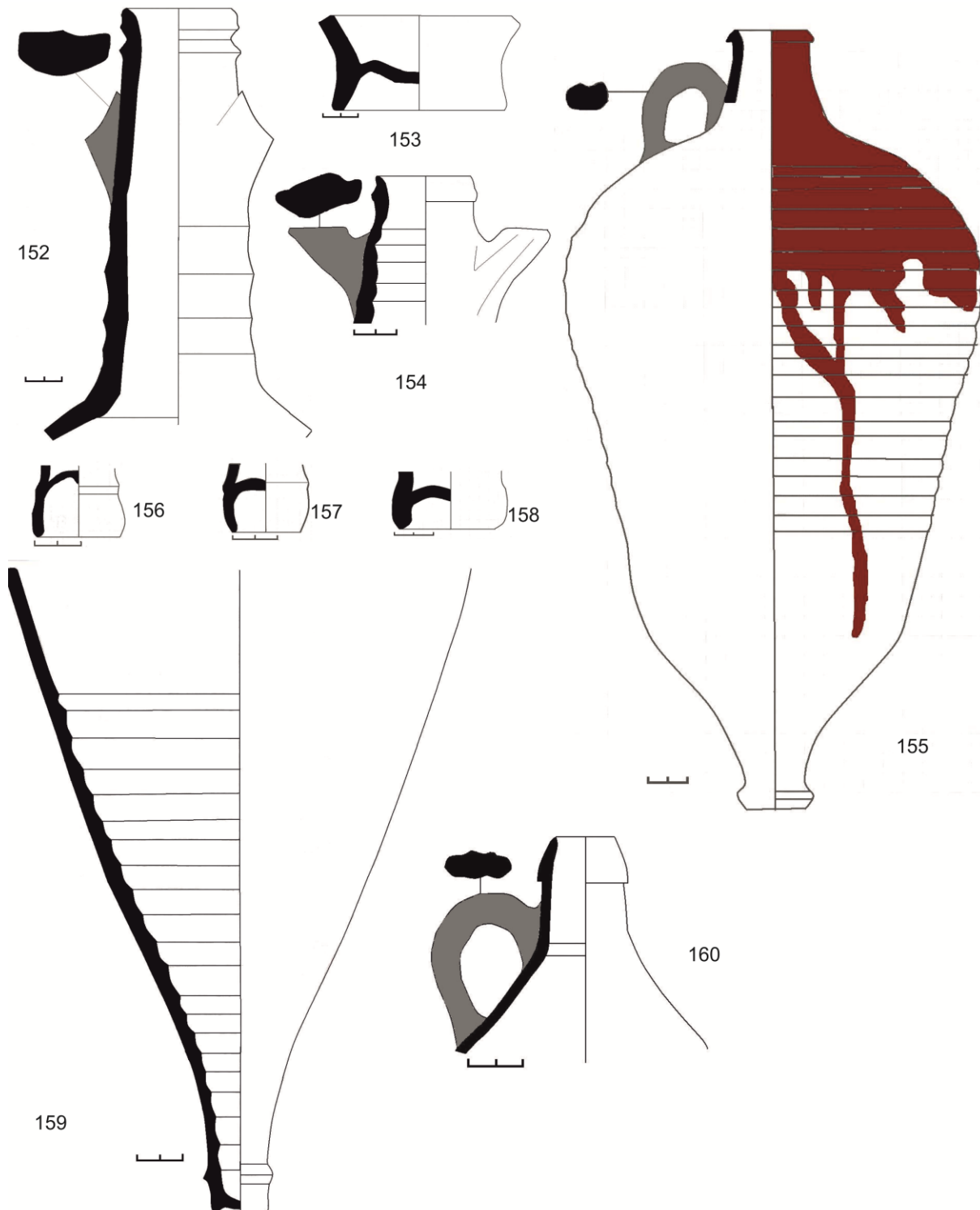

- 158.** T6, C3, amphora fragment, p.h.–3 cm, base d.–6 cm, oxidative firing, light beige fabric with small black particles, secondarily fired, Munsell 2.5Y 8/6 yellow, hollow conical foot;
- 159.** T9, amphora, fragment of base, p.h.–29 cm, base d.–2.5 cm, reduced firing, light grey fabric with silver mica and limestone particles in composition, rough aspect, Munsell 1 for Gley 5/1 greenish grey. The base is long and hollowed;
- 160.** T8, C3, amphora, a fragment of the upper part, rim and handle, r.d.–3.5 cm, p.h.–8 cm, semi-fine, brownish fabric with limestone particles and silver mica in composition, a single handle, oval in section, Munsell 5YR 5/8 yellowish red.

#### **Dressel 24 *similis*/ Early LR2**

- 161.** T6, C2, amphora, a fragment of the rim and neck, r.d.–13.5 cm, p.h.–11 cm, oxidative firing, reddish fabric with limestone particles, porous, yellowish coating, Munsell 7.5 8/4 pink, massif, funnel-shaped rim, presenting grooves at the inside;
- 162.** T3-T4, C3, Roman crypt, amphora, a fragment of the upper and median part, r.d.–13.5 cm, p.h.–20 cm, oxidative firing, reddish fabric with limestone particles, whitish coating, Munsell 7.5YR 8/3 pink (surface treatment) and Munsell 10 YR 7/8 yellow (the core). The rim is large, funnel-shaped, two red *dipinti* on different sizes of the neck, oval handle in section;
- 163.** T8, C3, amphora LR2 type, p.h.–19.5 cm, r.d.–10.5 cm, beige fabric with limestone particles in composition, traces of illegible red *dipinti*, Munsell 10YR 8/4 very pale brown. Funnel-shaped rim, oval handles in section, straight lines decoration on the body;
- 164.** T6, C3, amphora, a fragment of the rim, r.d.–18 cm, p.h.–14 cm, semi-fine reddish fabric with rare limestone particles, yellowish coating at the inside and outside, Munsell 2.5Y 8/8 yellow. Opaiț, Ionescu 2016, Dressel 24 *similis*, 67-68, pl. XIV/82-83, Opaiț 2007, fig. 8/42 (Dressel 24 *similis* D).

### **Occidental amphorae**

#### **Forlimpopoli**

- 165.** T6, C3, amphora,<sup>19</sup> Forlimpopoli type, almost complete excepting the missing base, p.h.–50 cm, r.d.–5.5 cm, oxidative firing, reddish fabric with limestone and black particles, whitish coating, the handles are oval in section, decorated with grooves, Munsell 10YR 8/8 yellow. The rim is faceted; the handles are arched, pear-shaped body presenting grooves.

#### **Dressel 20/23/38?**

- 166.** T6, C3, a fragment of the rim, p.h.–5 cm, r.d.–11 cm, oxidative firing, reddish semi-fine fabric containing limestone and black microparticles, homogenous, Munsell 7.5YR 8/6 reddish yellow.

---

<sup>19</sup> Gamureac 2017, 301-306.

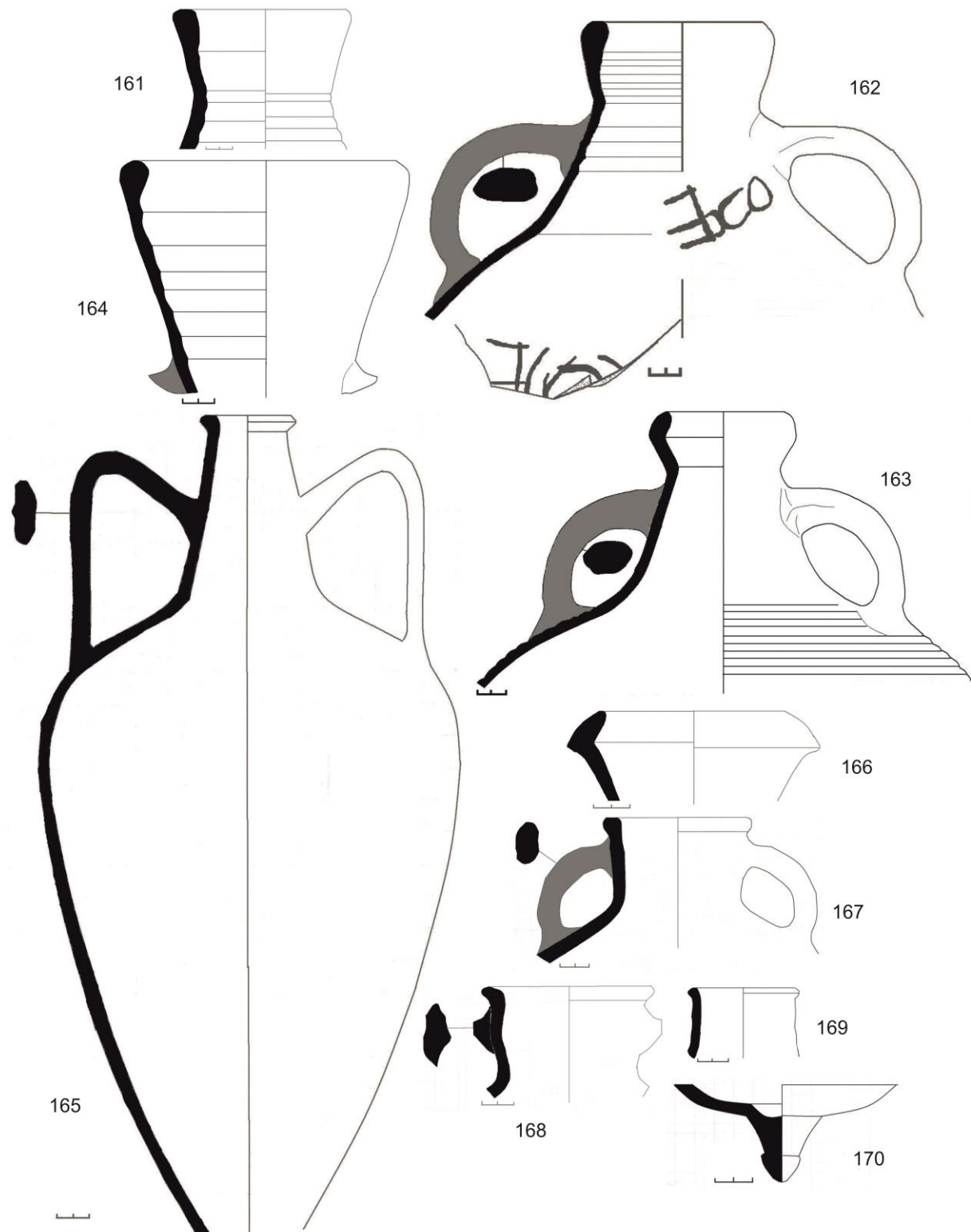

**Amphorae varia**

- 167.** T6, C3, amphora fragment of the upper part, p.h.–10 cm, r.d.–10 cm, oxidative firing, semi coarse reddish fabric containing sand and iron oxide particles, the surface treatment is at the same colour, Munsell 7.5YR 8/6 reddish yellow, the rim is thickened outwards, the neck is cylindrical, the handles are oval in section, decorated with grooves. Strictly from the shape point of view, close similarities with 4<sup>th</sup> c. AD Aegean amphora ToroneVII/Opaiț C-I;
- 168.** T6, C3, rim fragment, p.h.–7.5 cm, r.d.–11 cm, oxidative firing, reddish fabric with small black and iron oxide, the surface treatment is whitish, Munsell 5Y 8/4 pale yellow, the rim is thickened and facing outward, the neck is almost cylindrical, the handles are oval. Băjenaru 2014, 109, fig. 4/40, Aegean, (Histria, context of 1<sup>st</sup>-2<sup>nd</sup> c. AD); Opaiț, Ionescu, 2016, 65-66, pl. X/52 (Callatis);
- 169.** T6, C3, fragment of a amphora rim, p.h.–4,5 cm, r.d.–7 cm, oxidative firing, reddish semi-fine fabric containing limestone particles, Munsell 7.5YR 7/8 reddish yellow, the rim is facing outward;
- 170.** T6, C3, amphora, fragment of the lower portion, p.h.–5 cm, oxidative firing, reddish fabric containing limestone particles, Munsell 10YR 8/8 yellow, there is a small knob at the base of the amphora. Opaiț 1991, pl. 14/3-8 (Babadag Topraichioi);
- 171.** T6, C3, amphora, a fragment of the lower portion, p.h.–5 cm, oxidative firing, reddish fabric containing limestone particles, Munsell 10YR 8/8 yellow, there is a small knob at the base of the amphora. Opaiț 1991, pl. 14/3-8 (Babadag Topraichioi);
- 172.** T6, C3, amphora, a fragment of the upper part, r.d.–9 cm, p.h.–12 cm, oxidative firing, light reddish fabric with black microparticles in composition, granulated aspect, Munsell 10R 6/8 light red. The lip is slightly thickened to the outside, conic neck, oval handles in section, and stamp on the neck: CFYMOY;
- 173.** T8, C3B, amphora, fragment of rim, p.h.–6 cm, r.d.–10 cm, oxidative firing, semi-fine light brick colour with rare limestone particles, whitish coating at the outside, Munsell 5YR 7/6 reddish yellow (the core), and 2.5Y 8/2 pale yellow (coating). The rim is faceted; the handles are oval in section and decorated with grooves. Opaiț 1991, pl. 19/1, 3 (Babadag-Topraichioi);
- 174.** T16-T17, *passim*, amphora, a fragment of the lower part, p.h.–23 cm, maximum d.–19 cm, oxidative firing, brick colour fabric with black particles and limestone in composition, limestone deposits at the outside, Munsell 10R 6/8 light red. Traces of handles, the wall is unusually thick comparing with the size of the vessel (2 cm thickness), massive, the base is knobbed, presenting a button-shape. The amphora was filled in antiquity with mortar that hardened inside. Opaiț, Ionescu 2016, 67, pl. XII/67;
- 175.** T1, C1, amphora, a fragment of rim and neck, r.d.–6.5 cm, p.h.–13 cm, brown fabric with silver mica and limestone in composition, brown colour coating, oval handles in section, Munsell 5YR 6/8 reddish yellow;
- 176.** T17, fragment from an amphora wall, reddish sandy fabric, Munsell 7.5YR 8/6 reddish yellow, red *dipinti* letter K;
- 177.** T6, C5, amphora, a fragment of the rim, r.d.–12 cm, p.h.–7 cm, oxidative firing, reddish fabric with limestone microparticles, light brick colour coating, Munsell 7.5YR 8/2 pinkish white. Strictly concerning the profile of the rim, Zeest 1960, type 72 and 86 (2<sup>nd</sup>-3<sup>rd</sup> c. AD); Reynolds 2010, 90, fig. 2/e (Sinope/Heracleea Minor, early 3<sup>rd</sup> c. AD); Opaiț 1991, pl. 22/3 (Babadag–Topraichioi).

## NON-ROMAN TRADITION WARE

**178.** T6, C3, pot, rim fragment, p.h.–11.5 cm, r.d.–14 cm, oxidative firing, dark grey fabric porous, rudimentary, containing small fragments of stone, faceted rim in section, the rim becomes gently wider towards the top, cracked aspect, secondarily fired at the inside and outside, Munsell 7 YR 7/4 very pale brown;

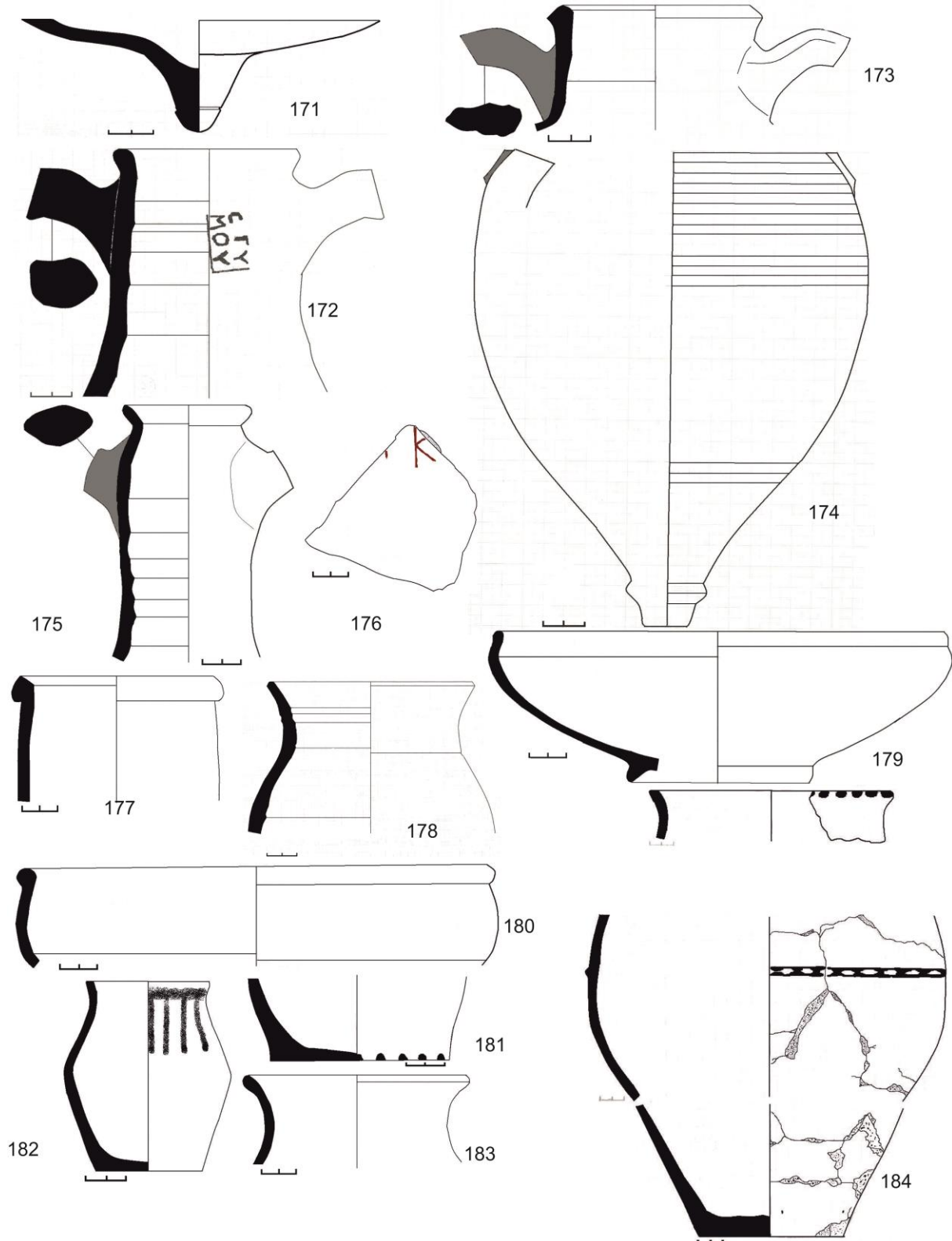



- 179.** T3-T4, bowl, fragment, r.d. 26 cm, p.h. 8,5 cm, semi-fine light greyish fabric with limestone particles and silver mica sparkles, polished at the outside, Munsell 1 for Gley 6/1 greenish-grey. Alexandrova 2013, bowls Type I, variant 3, 40, I-3/86, 2<sup>nd</sup> – 4<sup>th</sup> c. AD; Suceveanu 2000, type VI, pl. 9/46, (Histria, 1<sup>st</sup> – 2<sup>nd</sup> c. AD), type IX, pl. 11/7
- 180.** T1, C1, bowl, a fragment of rim and wall, r. d. 24 cm, p.h. 5 cm, coarse fabric with sand and limestone particles, brown-orange slip at the inside and outside, the slip is carelessly applied in a superficial manner, porous fabric, Munsell 2.5Y7/6 yellow;
- 181.** T6, C3, pot-jar, a fragment of the base, p.h. 4,5 cm, base d. 9 cm, coarse reddish fabric with small stones and sand in composition, handmade, secondarily fired at the outside and inside, Munsell 10R 3/6 dark red. The fragment presents decoration of alveoli at the exterior of the base;
- 182.** T6, C3, jar, complete profile, fragmentary condition, h. 9 cm, r.d. 6 cm, base d. 5 cm, coarse black fabric with limestone particles, secondarily fired at the outside and inside, handmade, decorated with parallel vertical polished lines on the upper part, Munsell 5YR 3/1 very dark grey;
- 183.** T1, C1, jar, rim fragment, p.h.–5 cm, r.d.–13 cm, coarse, black fabric with limestone particles, secondarily fired at the outside, handmade, Munsell 1 for Gley 2.5/1 greenish black;
- 184.** T8, C8, jar-pot, 3 fragments not joining of the rim, median part and base, r.d.–20 cm, base d.–12 cm, coarse brick colour fabric with small stones in composition, rough aspect, black slip at the outside, handmade. The vessel presents a decoration of alveoli at the rim and at the median part, the colour of the fabric is Munsell 5YR 6/8 reddish yellow and the slip colour is 2.5YR 2.5/1 reddish black. Baumann 1995, 156, pl. LV/12-13 (2<sup>nd</sup>-3<sup>rd</sup> c. AD).

## CONCLUDING REMARKS

The use of the pottery contributed to the establishing of the Roman way of life under the Roman rule at *Noviodunum (ad Istrum)* by the Roman culture of eating and drinking, to the main process of Romanization of the inhabitants.

The disposition of artefacts *in situ* was very important and the conclusions of this archaeological excavation will be drawn in further readings. As an example, all the lot of Aegean drinking and cooking wares (mugs, pitchers and pots), all characterized by unusually thin walls, were discovered in a single context – trench 6, pit no. 3, concluding that they were discarded in a single event and come from a single owner. Considering the similarities between the fabrics and forms of the potsherds, a possible logical conclusion is that this singular lot was imported from a single potter (or from an intermediate Aegean salesman) and was used in a single event (i.e. funerary banquet) or came from a single household. In this way a single pottery workshop may produce in the same style a large range of diverse utilitarian vessel, equally used for drinking, eating and cooking.

Regarding the pottery imports from other Roman provinces, they can be distinguished into two categories: the pottery imported for its utilitarian value and the recipients imported for their contents. In the case of wine amphorae, these containers were wholesaled, in theory, at prices equal to 0.5-1.3% of the wholesale cost of the wine destined to be packaged in them.<sup>20</sup>

---

<sup>20</sup> Peña 2007, 28.

Regarding the amphorae findings, the majority of them have Pontic origins, of which we note the Heraklean products. In second place are situated Oriental amphorae, of which Kapitän II, Carthage LRA 3 and Dressel 24 *similis*/early LRA 2 are present. The Occidental amphorae are poorly represented as Forlimpopoli almost singular example.

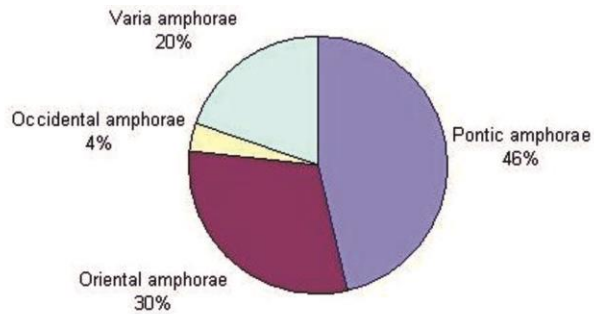

Percentage repartition of the amphorae by production zones

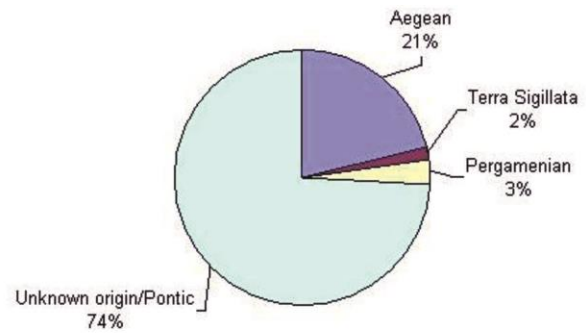

Percentage repartition of the pottery by production zones (excepting amphorae)



The archaeological excavations



View of the area of excavations

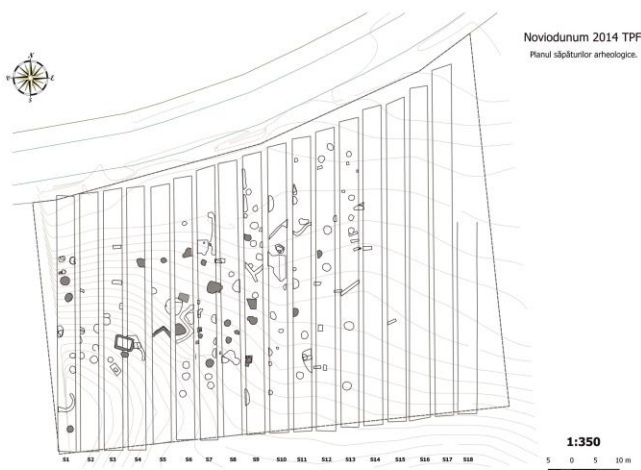

Plan of the excavated area



The Roman crypt

Although in antiquity Pontus was a part of the *Oriental pars* of the Roman Empire, we kept the traditional separation between Pontic, Oriental and Occidental products. Also, there are no accurate data about the exact place of pottery workshops producing a big part of the utilitarian drinking, eating and cooking wares. Considering that the form is travelling in

Roman times as long as the vessel itself, we assume that at least many of them were produced in the West Pontic provinces.



The luxury vessel as *terra sigillata* is poorly represented in our assemblage, but this fact emphasize the early presence of the Occidental imports at Noviodunum, as long previous studies established the same conclusion.<sup>21</sup> The Pergamenian/Çandarli forms and imitations are also represented by only a few examples. The Pontic Red Slip ware bowls, plates and pitchers falls within normal discoveries for 2<sup>nd</sup>-3<sup>rd</sup> c. AD discoveries, having analogies in other nearby Roman era sites as Aegyssus, Troesmis, Tomis or Histria.

Regarding the cooking utilitarian pottery, the main categories from this archaeological excavation are pots, casseroles and pans, many of them having probably Pontic origins, excepting a small group of them, identified as imported from the Aegean area.

The Getae culture pottery illustrates the artisanal traditional occupation of a population segment and was maintained until the 4<sup>th</sup> c. AD by the Getae - Dacians and Carpi tribes groups at the South of the Danube.<sup>22</sup>

---

<sup>21</sup> Baumann 2008, 192.

<sup>22</sup> Baumann 2009, 195.

**BIBLIOGRAPHY**

- Alexandrova, S. 2013, *Ceramic Vessels from the Roman Tumulus Necropolis near the Village of Charda, Yambol Municipality, SE Bulgaria*, *Archaeologia Bulgarica* 17 (3), 17-108.
- Băjenaru, C. 2013, *Contextes céramiques de Tomis. (I). Un ensemble de la fin du IIe - début du IIIe s. ap. J. C.*, *Pontica* 46, 41-110.
- Băjenaru, C. 2014, *Early Roman Pottery Groups from the Central Sector of the Late Roman City at Histria*, *Materiale și cercetări arheologice* 10, 105-131.
- Barnea, A. 1991, *Municipium Noviodunum*, *Peuce* 10, 81-84
- Barnea, I., Angheliescu, N., Mitrea, B. 1957, *Săpăturile de salvare de la Noviodunum*, *Materiale și cercetări arheologice* 4, 155-174
- Barnea, I., Barnea, A. 1984, *Săpăturile de salvare de la Noviodunum*, *Peuce* 9, 97-105.
- Baumann, V. H. 1995, *Așezări rurale antice în zona gurilor Dunării*, *Biblioteca Istro-Pontica. Seria Arheologie* 1, Tulcea.
- Baumann, V. H. 2008, *Despre începuturile vieții romane la Noviodunum*, *Peuce*, serie nouă 6, 189-206.
- Baumann, V.H. 2010, *Introducere în studiul ceramicii fine de la Noviodunum*, *Peuce*, Serie Nouă 8, 109-140.
- Baumann, V.H. 2009, *Producerea ceramicii locale la gurile Dunării în secolele I-IV p. Chr*, *Peuce*, Serie Nouă 7, 193-216.
- Baumann, V.H. 2017, *Cuptoare romane cu destinație specială pe teritoriul Noviodunens*, *Peuce*, Serie Nouă 15, 149-174.
- Bonifay, M. 1986, *Observations sur les amphores tardives de Marseille d'après les fouilles de la Bourse, (1980-1984)*, *Revue archéologique de Narbonnaise* 19, 269-305.
- Boțan, S.P., Paraschiv, D., Nuțu, G. 2010 *Vase de sticlă romane și romano-bizantine descoperite în Nordul Dobrogei*, *Arheologia Moldovei* 33, 217-242.
- Böttger, B. 1982, *Die Gefäßkeramik aus Kastell Iatrus*, in Böttger, B. (ed.), *Iatrus-Krivina: Spätantike Befestigung und frühmittelalterliche Siedlung an der unteren Donau, 2: Ergebnisse der Ausgrabungen 1966-1973*, Berlin, 33-148.
- Bounegru, O. 2006, *Trafiquants et navigateurs sur le Bas-Danube et dans le Pont Gauche à l'époque romaine*, Wiesbaden.
- Brukner, O. 1981, *Rimska keramika u Jugoslovenskom delu Provincije Donje Panonije*, *Dissertationes et monographiae* 24, Beograd.
- Chiriac, C., Boțan, P. 2013, *Sticlăria elenistică și romană din Pontul Euxin. Între producție și import*, in Panait Bîrzescu, Fl., Bîrzescu, I., Matei-Popescu, Fl., Robu, A. (eds.), *Poleis în Marea Neagră: Relații interpontice și producție locală*, București, 278-451.
- Ciașescu, M., Mustață, S. 2007, *The pottery from the Roman settlement*, in Mustață, S., Gogâltan, Fl., Cociș, S., Ursuțiu, A. (eds.), *Rescue excavation at Florești-Polus Center, Cluj County, Cluj-Napoca*, 243-278.
- Dyczek, P. 2001, *Roman Amphorae of the 1<sup>st</sup>-3<sup>rd</sup> centuries AD found on the Lower Danube. Typology*, Warszawa.
- Ertuğ Ergürer, H. 2018, *The fine pottery found in Parion Theater. A. Sigillata, Late Roman Red Slip Pottery and others*, in Bașaran, C., Ertuğ Ergürer, H. (eds.), *Parion studies I. Roman Theater of Parion. Excavations, Architecture and Finds from 2006-2015 Campaigns*, Çanakkale, 91-126.

- Gamureac, Ș.E. 2017, *A Forlimpopoli amphora type at Noviodunum*, in Nuțu, G., Ailincăi, S.-C., Micu, C. (eds.), *Omul, fluviul și marea. Studii de arheologie și istorie în onoarea lui Florin Topoleanu la a 65-a aniversare*, Cluj-Napoca, 301–306.
- Harizanov, A. 2020, *Socioeconomic aspects of ceramic production in Roman Thrace*, *Journal of Ancient History and Archaeology* 7 (2), 103-147.
- Hayes, J. W. 1972, *Late Roman Pottery*, The British School at Rome, London.
- Hayes, J. W. 2008, *The Athenian Agora 32. Roman Pottery: Fine-Ware Imports*, Princeton.
- Honcu, Ș. 2017, *Ceramica romană de bucătărie din Dobrogea, (secolele I-III p. Chr.)*, Constanța.
- Istenic, J., Schneider, G. 2000, *Aegean cooking ware in the Eastern Adriatic*, *Rei Cretariae Romanae Fautorum Acta* 36, 341-348.
- Kassab Tezgör, D. 2010, *Typologie des amphores sinopéennes entre les II<sup>e</sup>-III<sup>e</sup> s. et le VI<sup>e</sup> s. ap. J.-C.*, in Kassab Tezgör, D. (ed.), *Les fouilles et le matériel de l'atelier amphorique de Demirci près de Sinope. Recueil de travaux*, *Varia Anatolica* 22, Istanbul, 121-140.
- Klenina, E. 2006, *Ceramic tableware and kitchenware of the 3<sup>rd</sup>-6<sup>th</sup> century from Novae (Northern Bulgaria)*, *Novae. Studies and Materials II*, Poznan-Sevastopol.
- Lang, M. 1976, *The Athenian Agora XXI: Graffiti and Dipinti*. Princeton, the American school of classical studies at Athens
- Magie, D. 1950, *Roman Rule in Asia Minor*, Princeton.
- Mușețeanu, C., Elefterescu, D. 2004, *Contribuții privind ceramica romană de la Durostorum (IV)*, *Peuce, Serie Nouă* 2, 95-142
- Nagy, A. 2016, *Thin-walled pottery from the so-called Lágymányos workshop (South of Aquincum)*, *Rei Cretariae Romanae Fautorum Acta* 44, 633-641.
- Negru, M., Streinu, A. 2016, *Materiale arheologice romane*, in Negru, M., Schuster, C. (eds.), *ROMVLA I. Seria Rapoarte arheologice. Raport privind cercetările arheologice sistematice din 2015*, Târgoviște, 37-86.
- Nuțu, G., Costea, G. 2010, *Ceramică fină descoperită la Aegyssus*, *Peuce, serie nouă* 8, 147-168.
- Nuțu, G., Mihăilescu-Bârliba, L., Costea, I. 2014, *Roman pottery from Aegyssus: the tableware*, *Rei Cretariae Romanae Fautorum Acta* 43, 133-138.
- Nuțu, G., Stanc, S. M., Paraschiv, D. 2014, *Niculitel. A Roman Rural Settlement in North-East Moesia Inferior. Archaeological & Archaeozoological Research*, P, Kaiserslautern und Mehlingen.
- Okan, E., Bilir, A. 2020, *A group of Heraclea Pontica amphorae from the Late Antique bone workshop at Prusias ad Hypium Theatre*, *Peuce, Serie Nouă* 18, 333-355.
- Opaiț A. 2003, *'Table' Amphora Versus 'Table' Pitcher in Roman Dobrudja*, *Rei Cretariae Romanae Fautorum Acta* 38, 215-218.
- Opaiț, A. 1980, *Considerații preliminare asupra ceramicii romane timpurii de la Troesmis*, *Peuce* 8, 328-366.
- Opaiț, A. 1991, *Ceramica*, in Opaiț, A., Zahariade, M., Poenaru-Bordea, Gh., Opaiț, C., *Fortificația și așezarea romană târzie de la Babadag-Topraichioi*, *Peuce* 10, 211-260.
- Opaiț, A. 2004, *Local and Imported Ceramics in the Roman Province of Scythia (4<sup>th</sup>-6<sup>th</sup> centuries AD)*, *British Archaeological Reports. International Series* 1274, Oxford.



- Opaïț, A. 2007, *From DR 24 to LR2?* in Bonifay, M., Trégliat, J.-C. (eds.), *LRCW 2: Late Roman Coarse Wares, Cooking Wares and Amphorae in the Mediterranean: Archaeology and Archaeometry*, British Archaeological Reports. International Series 1662, Oxford, 627–643.
- Opaïț, A. 2010, *Pontic Wine in the Athenian Market*, in Παπανικόλα-Μπακιρτζή Δ, Κουσουλάκου, Ν. (eds.), *ΚΕΡΑΜΙΚΗ ΤΗΣ ΥΣΤΕΡΗΣ ΑΡΧΑΙΟΤΗΤΑΣ ΑΠΟ ΤΟΝ ΕΛΛΑΔΙΚΟ ΧΩΡΟ (3ος-7ος αι. μ.Χ.)*, Επιστημονική Συνάντηση, Θεσσαλονίκη, 12-16 Νοεμβρίου 2006, Θεσσαλονίκη, 108-130.
- Opaïț, A., Ionescu, M. 2016, *Contributions to the economic life of the city of Callatis in light of new ceramic finds (2<sup>nd</sup>-6<sup>th</sup> centuries AD)*, *Arheologia Moldovei* 39, 57-112.
- Ožanić Roguljić, I. 2008, *Roman coarse pottery from Cibalae (Vinkovici, Croatia): a typology*, *Acta Rei Cretariae Romanae Fautores* 40, 185-189.
- Paraschiv, D. 2006, *Amfore romane și romano-bizantine în zona Dunării de Jos (sec. I-VII p. Chr.)*, Iași.
- Paraschiv, D. 2013, *Les amphores romaines d'Héraclée du Pont en Dobroudja*, in Tsetskhladze, G.R., Atasoy, S., Avram, A., Dönmez, Ş., Hargrave, J. (eds.), *The Bosphorus: Gateway between the Ancient West and East (1st Millennium BC – 5th Century AD)*, *Proceedings of the Fourth International Congress on Black Sea Antiquities Istanbul, 14th-18th September 2009*, British Archaeological Reports. International Series 2517, Oxford, 213-217.
- Peña, T. 2007, *Roman Pottery in the Archaeological Record*, Cambridge -New York.
- Reynolds, P. 2010, *Trade networks of the East, 3<sup>rd</sup> to 7<sup>th</sup> centuries: the view from Beirut (Lebanon) and Butrint (Albania) (fine wares, amphorae and kitchen wares)*, in Menchelli, S., Pasquinucci, M., Santoro, S. (eds.), *Late Roman Coarse Wares, Cooking Wares and Amphorae in the Mediterranean. Archaeology and Archaeometry. Comparison between Western and Eastern Mediterranean* British Archaeological Reports International Series 2185, Oxford, 89-114.
- Robinson, H.S. 1959, *The Athenian Agora. Pottery of the Roman period. Chronology. The Athenian Agora. Results of excavations conducted by the American School of Classical Studies*, vol. V, Princeton.
- Rogers, G. B. 1999, *Poteries sigilées de la Gaule centrale. II, Les potiers*, Lezoux.
- Šelov, D. B. 1986, *Les amphores d'argile claire des premiers siècles de notre ère en Mer Noire*, in Empereur, J.Y., Garlan, Y. (eds.), *Recherches sur les amphores grecques*, Bulletin de correspondance hellénique. Supplément XIII, Athens, 395-400.
- Simion, G. 2007, *Le rapport entre les tombes de la nécropole tumulaire romaine et la société de Noviodunum au II<sup>ème</sup> ap. J.-C.*, *Istros* 14, 177-194.
- Simion, G. 1984, *Descoperiri noi in necropola de la Noviodunum*, *Peuce* 9, vol. I: 75-96; vol. II: 481-502.
- Simion, G. 1994, *Simion, Rituri și ritualuri practicate în necropola romană de la Noviodunum*, *Pontica* 27, 90-105.
- Suceveanu A. 2000, *Histria X. La céramique romaine des I<sup>er</sup>-III<sup>e</sup> siècles ap. J.-C.*, Bucarest.
- Suceveanu, A. 1998, *Fântânele. Contribuții la studiul vieții rurale în Dobrogea romană*, București.
- Sultov, B. 1985, *Ceramic production on the territory of Nicopolis ad Istrum (2<sup>nd</sup>-4<sup>th</sup> century)*, Sofia.

- Topoleanu F., *et alii* 2015, 124. *Iscacea, jud. Tulcea [Noviodunum] Punct: Cetate (Pontonul Vechi)*, *Cronica Cercetărilor Arheologice*. Campania 2014, București, 206-210.
- Topoleanu, F. 2018 (2020), *The pottery workshops at Noviodunum*, in Rusu-Bolindeț, V., Roman, C.-A., Iliescu, I.-Al., Botiș, Fl.-O., Gui, M., Mustață, S., Petruț, D. (eds.), *Atlas of Roman Pottery workshops from the Provinces Dacia and Lower Moesia/Scythia Minor (1<sup>st</sup>–7<sup>th</sup> centuries AD)*, II, Cluj-Napoca (in print).
- Topoleanu, F., Chrzanovsky, L. 2016, *O descoperire arheologică unică la Noviodunum: arhetipuri, tipare și producerea opaițelor*, Peuce, Serie Nouă 14, 145-158.
- Topoleanu, F., Chrzanovsky, L. 2016, *Une découverte lychnologique unique à Noviodunum (Tulcea, Roumanie): des archétypes, des moules et leurs productions...*, in Djaoui, D. (ed.), *Histoires matérielles : terre cuite, bois, métal et autres objets: des pots et des potes: Mélanges offerts à Lucien Rivet*, *Archéologie et Histoire Romaine*, 33, Autun, 181-192.
- Topoleanu, F., Gamureac, Șt.-E., Stănică, A. 2014, *Preliminary Considerations on Roman pottery from a rescue excavation at Noviodunum*, Peuce, Serie Nouă 12, 114-146.
- Topoleanu, F., Zahariade, M. 2017, *A note on a fragmentary list of names from Noviodunum*, *Pontica* 50, 407-414.
- Więch, M. 2017, *Searching for the Kitchen in the Early Roman Phase of the 'Hellenistic' House at Nea Paphos (Cyprus)*, *Études et Travaux* 30, 439–457.
- Zhuravlev, D. V. 2002, *Terra Sigillata and red slip pottery in the North Pontic region (a short bibliographical survey)*, *Ancient Civilizations from Scythia to Siberia* 8 (3-4), 237-309.
- Zhuravlev, D. V. 2009, *Pontic Sigillata Plates with a Vertical Rim from the Belbek IV Necropolis in the South-Western Crimea*, *Ancient Civilizations from Scythia to Siberia* 15 (1-2), 25-94.
- \*
- Зеест, И.Б. 1960, *Керамическая тара Боспора*, *Материалы и исследования по археологии СССР* 83, Москва.